



SolarEdge

SolarEdge

Electricity Meter

Installation Guide

For North America
Version 1.0

Disclaimers

Important Notice

Copyright © SolarEdge Inc. All rights reserved.

No part of this document may be reproduced, stored in a retrieval system or transmitted, in any form or by any means, electronic, mechanical, photographic, magnetic or otherwise, without the prior written permission of SolarEdge Inc.

The material furnished in this document is believed to be accurate and reliable. However, SolarEdge assumes no responsibility for the use of this material. SolarEdge reserves the right to make changes to the material at any time and without notice. You may refer to the SolarEdge web site (<http://www.solaredge.us>) for the most updated version.

All company and brand products and service names are trademarks or registered trademarks of their respective holders.

Patent marking notice: see <http://www.solaredge.us/groups/patent>

The general terms and conditions of delivery of SolarEdge shall apply.

The content of these documents is continually reviewed and amended, where necessary. However, discrepancies cannot be excluded. No guarantee is made for the completeness of these documents.

The images contained in this document are for illustrative purposes only and may vary depending on product models.

FCC Compliance

This equipment has been tested and found to comply with the limits for a Class B digital device, pursuant to part 15 of the FCC Rules. These limits are designed to provide reasonable protection against harmful interference in a residential installation. This equipment generates, uses and can radiate radio frequency energy and, if not installed and used in accordance with the instructions, may cause harmful interference to radio communications. However, there is no guarantee that interference will not occur in a particular installation. If this equipment does cause harmful interference to radio or television reception, which can be determined by turning the equipment off and on, you are encouraged to try to correct the interference by one or more of the following measures:

- Reorient or relocate the receiving antenna.
- Increase the separation between the equipment and the receiver.
- Connect the equipment into an outlet on a circuit different from that to which the receiver is connected.
- Consult the dealer or an experienced radio/TV technician for help.

Changes or modifications not expressly approved by the party responsible for compliance may void the user's authority to operate the equipment.

Contents

Disclaimers	1
Important Notice	1
FCC Compliance	1
Contents	2
HANDLING AND SAFETY INSTRUCTIONS	3
Safety Information	3
Chapter 1: Introduction	4
Terminology	4
The SolarEdge Electricity Meter	5
Meter Connection Options	6
Chapter 2: Meter Installation	7
Installation Guidelines	7
Installing and Connecting the Meter	7
Chapter 3: SolarEdge Device Configuration	12
Appendix A: Troubleshooting Meter Connection	15
Communication Status Screen Troubleshooting	15
Device Type or Protocol are configured incorrectly	15
Number of devices is not displayed	15
Meter Status Screen Troubleshooting	15
<OK> is not displayed	16
An error message is displayed	16
Total [Wh] value is not advancing	16
Meter Status LEDs	17
Power Status LEDs	17
Modbus Communication LEDs	18
Appendix B: Installing Two Meters	19
Connecting Two Meters	19
Configuring Dual-meter Connection	19
Verifying Meter Connection	20
Troubleshooting Dual-meter Connection	21
Communication Status Screen Troubleshooting	21
Device Type or Protocol are configured incorrectly	21
Number of devices is lower than configured or not displayed	21
Meter Status Screen Troubleshooting	21
Appendix C: Meter Information Displayed in the Monitoring Portal	22
Appendix D: Meter Technical Specifications	23
Appendix E: External Lightning Protection Connection	24

HANDLING AND SAFETY INSTRUCTIONS

During installation, testing and inspection, adherence to all the handling and safety instructions is mandatory. **Failure to do so may result in injury or loss of life and damage to the equipment.**

Safety Information

The following safety symbols are used in this document. Familiarize yourself with the symbols and their meaning before installing or operating the system.

WARNING!



Denotes a hazard. It calls attention to a procedure that, if not correctly performed or adhered to, could result in **injury or loss of life**. Do not proceed beyond a warning note until the indicated conditions are fully understood and met.

Dénote un risque: il attire l'attention sur une opération qui, si elle n'est pas faite ou suivi correctement, pourrait causer des blessures ou un danger de mort. Ne pas dépasser une telle note avant que les conditions requises soient totalement comprises et accomplies.

CAUTION!



Denotes a hazard. It calls attention to a procedure that, if not correctly performed or adhered to, could result in **damage or destruction of the product**. Do not proceed beyond a caution sign until the indicated conditions are fully understood and met.

Dénote un risque: il attire l'attention sur une opération qui, si elle n'est pas faite ou suivi correctement, pourrait causer un dommage ou destruction de l'équipement. Ne pas dépasser une telle note avant que les conditions requises soient totalement comprises et accomplies.

NOTE



Denotes additional information about the current subject.

IMPORTANT SAFETY FEATURE



Denotes information about safety issues.

Chapter 1: Introduction

Terminology

The following terms are used in this document:

- **Export:** The power injected to the grid.
- **Import:** The power purchased from the grid.
- **Export/ Import meter:** A meter that is installed at the grid connection point and reads the energy/power exported/imported to/from the grid.
- **Consumption:** The power consumed by the site.
- **Consumption meter:** A meter that is installed at the load consumption point and reads the energy/power consumed by the site.
- **Self-consumption:** The PV power consumed by the site and not fed into the grid.
- **Production:** The PV power produced by the PV system.
- **Production meter:** A meter that is installed at the inverter output or in the inverter (a built-in revenue grade meter) and reads the energy/power produced by the PV system.

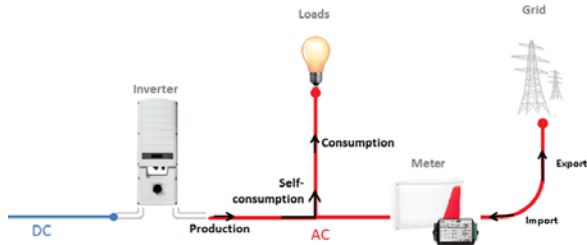

Figure 1: Terminology

The SolarEdge Electricity Meter

The SolarEdge meter enables measuring the power and energy of the photovoltaic (PV) system.

The meter is used by the inverter for the following applications:

- Consumption monitoring
- Export limitation
- StorEdge Smart Energy Management on-grid applications

The meter is built into an enclosure and requires two Current Transformers (CTs; available from SolarEdge).

The SolarEdge inverter or the Control and Communication Gateway (CCG) reads the exported power from a meter installed at the grid connection point or reads the consumption from a meter installed at the load consumption point.

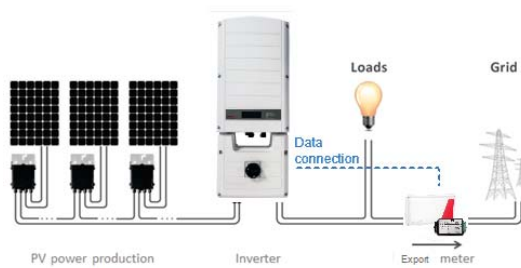

Figure 2: Typical installation with export meter

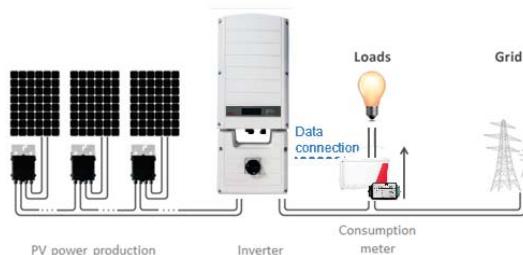

Figure 3: Typical installation with consumption meter

Meter Connection Options

In a *single* inverter system, the meter is connected directly to the inverter. If your inverter has a built-in revenue grade meter (RGM; the inverter is referred to a revenue grade inverter), you can connect an external meter on the same bus as the RGM (available from SolarEdge).

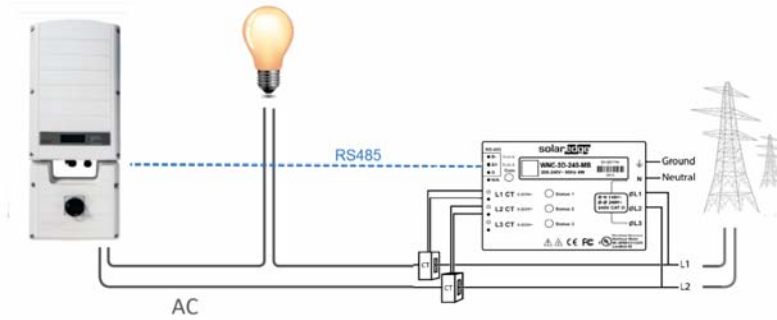

Figure 4: Single-inverter connection

In a *multiple* inverter system, two options are available:

- The meter is connected to the RS485 port of one of the inverters. In this case, as the inverter's RS485 port is occupied by the meter, use an RS485 Expansion Kit (available from SolarEdge) or ZigBee communication between the inverters.
- The meter is connected to one of the RS485 ports of a CCG. The CCG's second RS485 port can be used to create an RS485 bus for communication between the inverters. This option is illustrated in *Figure 5*.

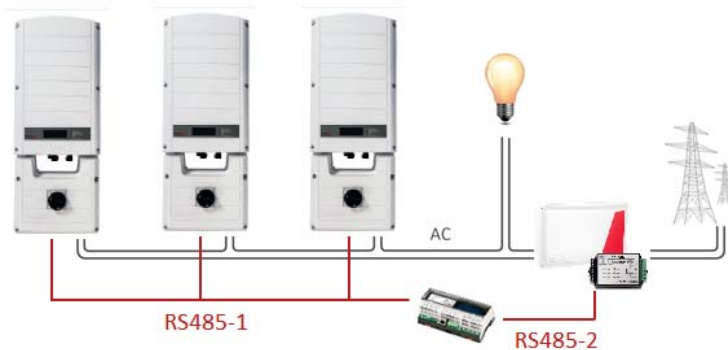

Figure 5: Multi-inverter connection with CCG and meter

Chapter 2: Meter Installation

The meter is connected to the inverter using RS485.

Installation Guidelines

AC wire specifications: 1.3 to 2.0 mm diameter / 16-12 AWG stranded wire, 600 V, type THHN, MTW, or THWN.

RS485 wiring specifications:

- Cable type: Min. 3-wire shielded twisted pair (a 4-wire cable may be used)
- Wire cross-section area: 0.2- 1 mm² / 24-18 AWG (a CAT5 cable may be used)

NOTE



If using a cable longer than 10 m/33 ft in areas where there is a risk of induced voltage surges by lightning, it is recommended to use external surge protection devices. For details refer to *External Lightning Protection Connection* on page 24. If grounded metal conduit are used for routing the communication wires, there is no need for a lightning protection device.

- The meter is considered “permanently connected equipment” and requires a disconnect means (circuit breaker, switch, or disconnect) and overcurrent protection (fuse or circuit breaker).
- The meter draws 10-30mA, therefore the rating of any switches, disconnects, fuses, and/or circuit breakers is determined by the wire gauge, the mains voltage, and the current interrupting rating required.
- The switch, disconnect, or circuit breaker must be located near the meter and be easily operated .
- Use circuit breakers or fuses rated for 20A or less.
- Use grouped circuit breakers when monitoring more than one line.
- The circuit breakers or fuses must protect the mains terminals labeled L1, L2, and L3. In the rare cases where neutral has overcurrent protection, the overcurrent protection device must interrupt both neutral and the ungrounded conductors simultaneously.
- The circuit protection / disconnect system must meet all national and local electrical codes.

Installing and Connecting the Meter

Mount the meter on a wall or pole using the supplied bracket.

► To mount the meter:

1. Install the bracket with the semi-circles facing down, as shown below. Verify that the bracket is firmly attached to the mounting surface.

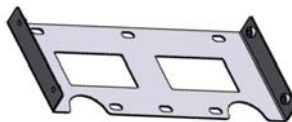

Figure 6: Mounting bracket

- Loosen the 4 Allen screws of the meter enclosure and remove the cover.

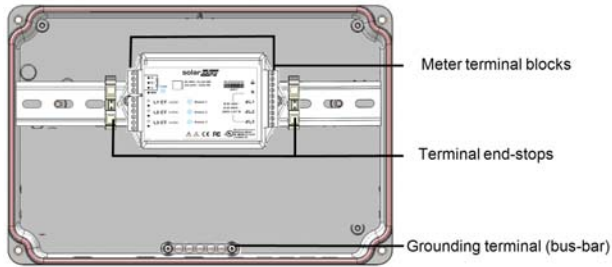

Figure 7: Meter front view without cover

- Carefully move the terminal block end-stops to the sides of the meter and remove the terminal blocks.
- Open one or more conduit knockouts according to the conduits used in the installation: Open the required knockout(s), each with two sizes: 3/4" and 1", taking care not to interfere with any of the internal components. A Unibit drill may be used.

CAUTION!



Use only knockouts located at the bottom, back and sides of the enclosure. Opening the top knockouts may damage the protection rating of the enclosure.

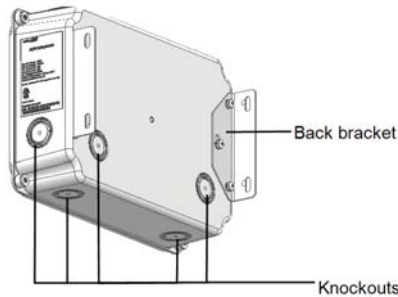

Figure 8: Meter - rear view

- Mount the meter: Attach the meter enclosure back brackets to the mounted bracket using the four supplied screws. Tighten the screws with a torque of 9 N*m / 6.6 lb*ft.

▶ To install the CTs:

- Turn off AC power before clamping on current transformers.
- Install the CTs around the conductor to be measured. Split-core CTs can be opened for installation around a conductor. A nylon cable tie may be secured around the CT to prevent accidental opening.
- Install the CT with the arrow pointing to the grid for consumption or export measurement.

► To wire the meter:

If you are connecting the meter to a revenue grade inverter, refer to *Installing Two Meters* on page 19. Refer to the connection diagram below:

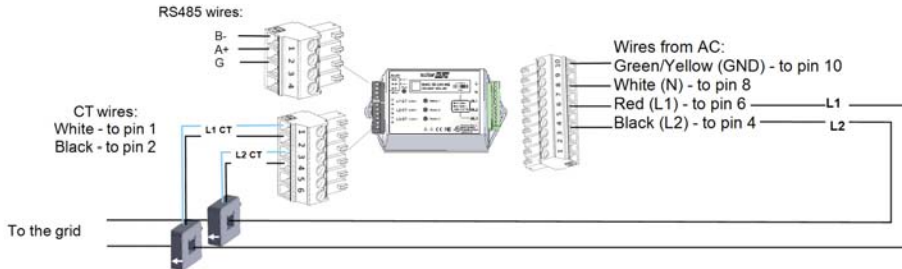

Figure 9: Meter connections



NOTE

- Clamp the CT connected to **L1 CT** around the wire connected to **ØL1**.
- Clamp the CT connected to **L2 CT** around the wire connected to **ØL2**.

1. Verify that power is OFF before making connections.
2. Insert a grounding cable through the appropriate conduit and the knockout that was opened and connect it from Pin 10 of the 10-pin terminal block to the grounding terminal (bus-bar) at the bottom of the meter enclosure.
3. Connect the AC side wires (meter input) using the 10-pin terminal block:
 - a. Insert the wires through the appropriate conduit and the knockout that was opened.
 - b. Loosen the appropriate screws on the 10-pin terminal block.
 - c. Connect each AC wire to the appropriate screw terminal (pins 6, 4). Verify that the lines match the symbols printed on the meter front label.
 - d. Connect ground to pin 10 and neutral to pin 8.
 - e. Tighten the screws making sure the wires are fully inserted and cannot be pulled out easily.
 - f. Insert the 10-pin terminal block into the socket on the meter making sure it is fully seated in the meter.
4. Connect the CT wires to the 6-pin terminal block:
 - a. Insert the wires through the appropriate conduit and the knockout that was opened.
 - b. Connect the black and white wires according to the dots printed on the label: White to L1/L2 white (pins 1/3), and black to L1/L2 black (pins 2/4).
 - c. Insert the 6-pin terminal block into the socket on the meter making sure it is fully seated in the meter
5. Connect the RS485 twisted pair cable to the 4-pin terminal block of the meter:
 - a. Insert the wires through the appropriate conduit and the knockout that was opened.
 - b. Connect the wires to the A+ and B- terminals, and connect the shield to the G terminal.
 - c. Insert the 4-pin terminal block into the socket on the meter making sure it is fully seated in the meter
6. Return the terminal block end-stops to the sides of the meter.

▶ To connect the meter to the inverter or CCG:

1. If connecting to an inverter, remove the seal from one of the openings in communication gland #2 at the bottom of the inverter and insert the RS485 wires from the meter through the opening.

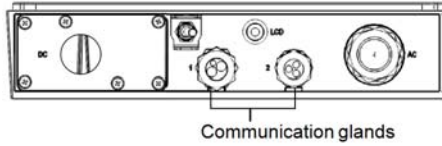

Figure 10: Communication glands

2. Prepare to connect to one of the available RS485 ports of the device, as shown below:
 - Inverter RS485-1 - pull out the 9-pin RS485 connector located on the communication board.

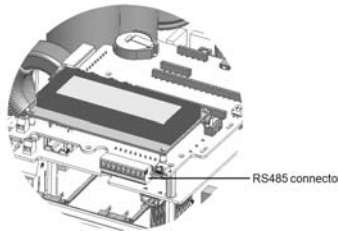

Figure 11: Inverter RS485 connector

- Inverter RS485 Expansion module - pull out the 3-pin connector

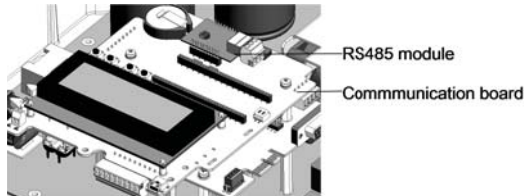

Figure 12: Inverter RS485 Expansion module

- CCG - use one of the 3-pin connectors supplied with the CCG. Connect it to the RS485-2 connection on the CCG.

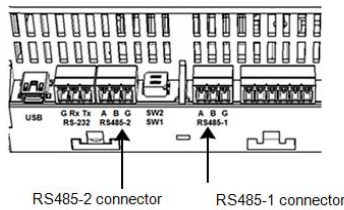

Figure 13: CCG RS485 connector

3. Connect the wires as shown below:

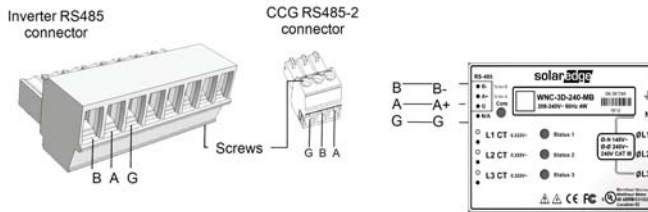

Figure 14: Meter RS485 connections

4. If the SolarEdge device is at the end of the RS485 bus, terminate as follows:

- Inverter - Terminate by switching a termination DIP-switch inside the inverter to ON (top position). The switch is located on the communication board and is marked SW7.
- CCG - Terminate by switching the SW2 termination DIP-switch to ON.

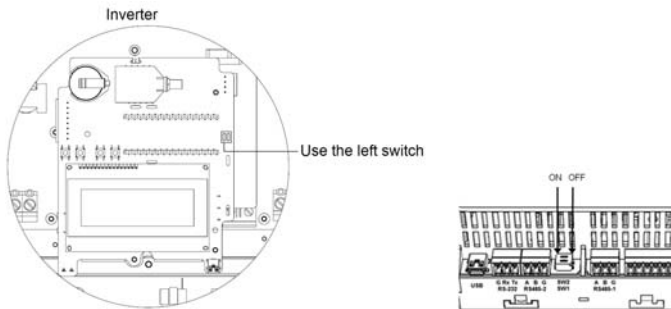

Figure 15: RS485 termination switch

Chapter 3: SolarEdge Device Configuration

This section describes basic configuration of SolarEdge devices (inverter/CCG) for using a meter. In addition, configuration specific to the application being used is required in some cases. Refer to the following documents:

- Export Limitation - http://www.solaredge.us/files/pdfs/products/export_limitation_application_note_NA.pdf
- Consumption and Production Monitoring - http://www.solaredge.us/files/pdfs/products/consumption_production_monitoring_application_note.pdf
- StorEdge Smart Energy Management off-grid applications - http://www.solaredge.us/files/pdfs/storedge_backup_installation_guide_NA.pdf.

For configuring two connected meters refer to *Installing Two Meters* on page 19.

▶ To configure the SolarEdge device:

Use the four user buttons to control the LCD panel menus:

- **Esc**: Goes to the beginning of the currently entered parameter or to the previous menu.
- **Up** (1) and **Down** (2): Moves the cursor (>) to the relevant menu option.
- **Enter** (3): Used to select an option

1. Verify that the device ON/OFF switch is OFF.
2. Turn ON the AC switch of the main circuit board.

WARNING!



ELECTRICAL SHOCK HAZARD. Do not touch uninsulated wires when the inverter cover is removed.

RISQUE D'ÉLECTROCUTION, ne touchez pas les fils non isolés lorsque le couvercle de l'onduleur est retiré.

3. Press the Enter (3) button for at least five seconds. The following message is displayed:

```

Please enter
Password
*****

```

4. Use the three right most buttons (Up-1, Down-2 and Enter-3) to type in the following default password: **12312312**.
5. Scroll to the **Communication** menu and select **RS485-X Conf** (X represents the actual RS485 port to which the electricity meter is connected: 1 or E for the inverter; 1 or 2 or E for the CCG). The following screen is displayed:

```

Device Type <SE>
Protocol <M>
Device ID <1>
Slave Detect <#>
Slave List <#>

```

6. Select **Device Type**. the following screen is displayed:

```
SolarEdge <M>
Non-SE Logger <S>
Revenue Meter <M>
Multi-devices <M>
None
```

7. Select **Revenue Meter**, the following screen is displayed:

```
Device Type <MTR>
Protocol <WN>
Device ID <1>
CT Rating <0>
Meter Func. <None>
```

8. Configure the meter parameters as follows:

- Select **Protocol** → **WattNode**.
- Select **Device ID: 2**
- Set the CT rating to the value that appears on the CT: **CT Rating** → **<xxxxA>**. The default is 5 Amperes. If the displayed rating is 0 or you cannot change the value, there is no communication with the meter. Check that the AC power to the meter is on.
- Select **Meter Func.** and select one of the functionality options, according to the installed meter specifications and location.

```
Export+Import
Export
Consumption
Production
Import
None
```

- **Export+Import:** The meter is installed at the grid connection point and reads pulses from both directions - export and import energy.
- **Export:** The meter is installed at the grid connection point and reads the export energy.
- **Consumption:** The meter is installed at the load consumption point and reads the energy consumed by the site.
- **Production:** The meter is installed at the inverter output and reads the energy produced by the inverter.
- **Import:** The meter is installed at the grid connection point and reads the import energy.
- **None:** No reading

The selected option is displayed in the RS485 Conf screen as <E+I>, <E>, <Cons>, <Prod>, <I>, <None>.

9. Exit Setup mode.

NOTE



Calculated meter readings, such as self-consumption, are calculated using the data measured by the meter and the inverters. Calculated meters are only sent when Energy Manager is enabled (for details refer to http://www.solaredge.us/files/pdfs/products/export_limitation_application_note_NA.pdf).

▶ To verify meter connection:

1. Press the Enter button or the LCD external button until the Communication status screen is displayed as shown below. This screen shows the number of external devices that communicate on each port, the device type, and the protocol to which each port was configured.
2. Verify that the setting of the relevant RS485 port is correct and that the port is communicating with the meter.
For example, if the meter is connected to the RS485-1 port, the Communication status screen should display the following:

```

      Dev Prot ##
RS485-1 <MTR><WN>< 1>
RS485-2 <---><---><--->
ZigBee <---><---><--->

```

Dev: the type of device configured to this port. **MTR** indicates a meter.

Prot: the communication protocol

= 1: Indicates that the connection to the meter is successful.

3. Press the Enter button or the LCD external button until reaching the meter status screen showing the total energy [Wh]. If there is more than one meter/function, there is a status screen for each one. The following is an example of an Export meter:

```

Export Meter
Status:      <OK/Error#>
Power [W] :   xxxxx.x
Energy [Wh] :  XXXXX.X

```

Status: Displays OK if the meter is communicating with the inverter.

<Error message>: If an internal meter error occurs, it will be displayed here. Refer to *Troubleshooting Meter Connection* on the facing page.

Total [Wh]: Displays the accumulated lifetime energy of the meter.

If the SolarEdge device is connected to the SolarEdge server this value will also be displayed in the monitoring portal.

▶ To display the meter serial number:

1. Enter Setup mode and select **Information**. The following screen is displayed:

```

Versions
Error Log
Warning log
Hardware IDs

```

2. Select **Hardware IDs**. The following is displayed showing the ID of the inverter and any meter connected to it:

```

ID 5000FFFF 4E
RGM: 12345678

```

Appendix A: Troubleshooting Meter Connection

SolarEdge revenue grade inverters have a built in Revenue Grade Meter (RGM). For troubleshooting RGMs, refer to http://www.solaredge.com/files/pdfs/built-in_rgm_troubleshooting.pdf. This section describes how to troubleshoot meter-related installation and performance errors.

Communication Status Screen Troubleshooting

The communication status screen should display the following:

```

      Dev Prot ##
RS485-1 <MTR><WN>< 1 >
RS485-2 <---><---><--->
ZigBee  <---><---><--->
  
```

Device Type or Protocol are configured incorrectly

If **MTR** (meter) is not displayed as the device type (DEV), or **WN** (WattNode) is not displayed as the Prot (protocol), configure the meter as follows.:

1. Select **Communication** → **RS485-x Conf** → **Device Type** → **Revenue Meter**.
2. Select **Communication** → **RS485-x Conf** → **Protocol** → **WattNode**.
3. Check that the Device ID under **Communication** → **RS485-x Conf** → **Device ID** is set to 2.
4. Select **Revenue Meter** → **Meter Func.** → **Export+Import / Export / Import / Consumption**.

Number of devices is not displayed

If <--> is displayed under the ## column in the Communication status screen, the meter is not communicating with the inverter. Check the following:

- The meter configuration is as described above.
- There are no loose connections at the inverter connectors and at the meter, specifically the RS485 wiring.
- The wiring between the black 4-pin terminal block on the meter and the RS485 terminal block on the communication board is correct, as shown in *Figure 9*.
- Check for water damage or sealing problems:
 - Inspect the entire conduit run for possible points of water penetration, and fix leaks.
 - Ensure that proper outdoor rated components are used.
- Use a Voltmeter to measure the voltage on the meter 10-pin terminal block . The L1 – L2 line to line voltage should be 208-240Vac .

Meter Status Screen Troubleshooting

```

Production Meter
Status:          <OK/Error>
Power [W] :      xxxxxx.x
Energy [Wh] :    xxxxxx.x
  
```

<OK> is not displayed

If <OK> is not displayed in the Status line of the status screen shown above, the meter is not communicating with the inverter. Check the following:

- There are no loose connections at the inverter communication board and at the meter.
- The wiring between the black 4-pin terminal block on the meter and the RS485 terminal block on the communication board is correct.
- Check for water damage or sealing problems:
 - Inspect the entire conduit run for possible points of water penetration, and fix leaks.
 - Ensure that proper outdoor rated components are used.

An error message is displayed

- If **Comm. Error** is displayed in the meter status screen, verify proper connection of:
 - The RS485 cables and connectors
 - The AC connection of the meter
- If **Error 185 Meter Comm. Error** message is displayed, contact SolarEdge support.

Total [Wh] value is not advancing

If the Total [Wh] value displays a steady value although the inverter is producing power, check the following:

- There are no loose connections at the inverter connectors and at the meter, specifically the AC wiring on the meter 10-pin connector.
- The CT black and white cables are correctly connected to the 6-pin connector on the meter:
 - White CT wire is connected to the L1/L2 white dot.
 - Black CT wire is connected to the L1/L2 black dot.
- The L1/L2 cable passes through the CT in the correct direction (right to left), according to the arrow on the inside of the CT.

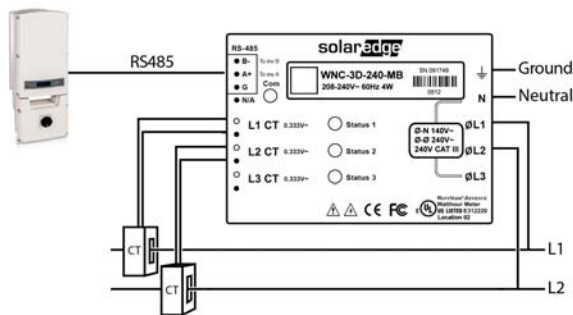

Figure 16: Meter Connection diagram

- Check for water damage or sealing problems:
 - Inspect the entire conduit run for possible points of water penetration, and fix leaks.
 - Ensure that proper outdoor rated components are used.

Meter Status LEDs

Power Status LEDs

The three status LEDs on the front of the meter can help indicate correct measurements and operation.

- Normal operation indications:
 - At normal startup - when power is first applied, all the LEDs light up sequentially for 1 sec.
 - The following table describes LED indications during normal operation:

LED color	Function	Indication
Red	Flashing ON/OFF	Appears only when the meter is connected at the grid connection point (CT directed towards the grid). Indicates export power measurement.
Yellow	Flashing	Communication OK
Green	Flashing ON/OFF	<ul style="list-style-type: none"> ◦ When the meter is connected at the grid connection point it indicates import power measurement (CT directed towards the grid). ◦ When the meter is connected at the load connection point it indicates consumption power measurement (CT directed towards the grid). ◦ When the meter is used for production it indicates production power measurement (CT directed toward the inverter).
	ON for >3 sec	No current flow (zero current)

- Abnormal operation indications:
 - If all LEDs are off – the meter is not operating. Perform all troubleshooting steps starting with checking the physical connections.
 - The following table describes additional LED indications that require troubleshooting and repair.

LED color	Function	Indication	Troubleshooting
Red	ON for >3 sec.	Internal error	Contact SolarEdge Support.
	Flashing ON/OFF	Negative power for the phase	If the meter is connected at the load connection point or if the meter is used for production metering, check for reversed CTs, swapped CT wires, or CTs not matched with the lines.
	Flashing with green LED	Voltage is too high for this model	Disconnect power immediately! Check the line voltages and the meter ratings.
Yellow	Flashing with yellow LED	The line voltage is out of range (Vac \pm 20%). Specifically, the voltage is too low for the meter to operate correctly and the meter reboots repeatedly.	Verify that the voltage on the Vac screw terminals is within the range of \pm 20% of the nominal operating voltages printed in the white rectangle on the front label.
	ON for >3sec.	Power line frequency is below 45 Hz or above 70 Hz.	Check for the presence of high noise, for example, the meter is too close to an unfiltered variable frequency drive.
	Flashing with red LED	Voltage is too high for this model	Disconnect power immediately! Check the line voltages and the meter ratings.

Modbus Communication LEDs

The communication LED is located at the upper left corner. The following are indications of the LED light:

LED color	Function	Indication	Troubleshooting
Red	Flashing	An invalid packet: bad baud rate, bad CRC, noise, bad parity, etc.	Check that the communication wires are connected correctly.
	ON	The address is set to zero: an invalid choice	Check that the Device ID is set to 2 in the RS485 Conf screen.
	Flashing with yellow LED	A possible address conflict (two devices with the same DIP switch address).	Check that the Device ID is set to 2 in the RS485 Conf screen.
Yellow	Flashing	Valid packets addressed to different devices.	N/A
Green	Flashing	A valid packet addressed to this device	N/A

Appendix B: Installing Two Meters

This section describes connecting an external meter to an inverter equipped with a built-in Revenue Grade Meter (RGM), which is located in the Safety Switch. RS485 wiring is daisy-chained between the two meters and the inverter.

Connecting Two Meters

1. Connect the external meter to the RGM as shown in *Figure 17*:
 - a. Route the external meter wires through one of the Safety Switch conduits (it is recommended to use the DC side conduits).
 - b. Connect the external meter wires together with the RGM wires to the same screw terminals of the RGM RS485 terminal block:
 - Remove the RGM wires from the terminals (note the wire color and location).
 - Twist the wires together and insert them into the terminal.
 - Securely tighten the terminal screws.

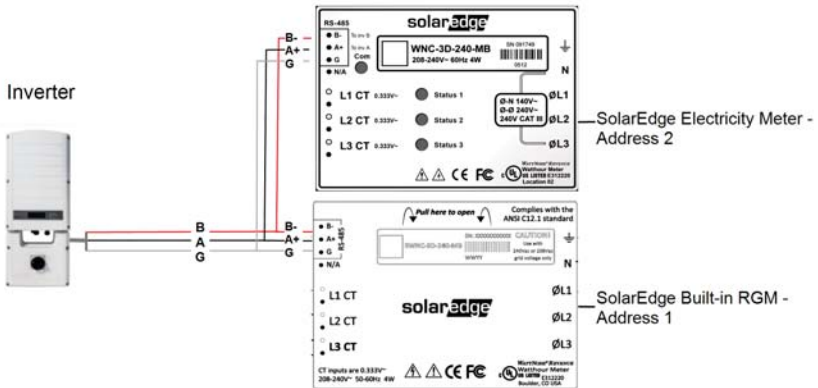

Figure 17: Meters connection to an RGM inverter

2. Terminate the SolarEdge device as described in *Installing and Connecting the Meter* on page 7.

Configuring Dual-meter Connection

The built-in RGM is pre-configured as a production meter and its settings should not be changed. Verify the pre-configured parameters of the RGM and configure the parameters of the external meter as described below.

1. Enter Setup mode, scroll to the **Communication** menu and select **Communication** → **RS485-x Conf.**
The following screen is displayed:

```

Device Type <SE>
Protocol <M>
Device ID <1>
Slave Detect <#>
Slave List <#>
    
```

2. Select **Device Type**. the following screen is displayed:

```
SolarEdge <M>
Non-SE Logger <S>
Revenue Meter <M>
Multi-devices <M>
None
```

3. Select **Multi Devices**. The following screen is displayed:

```
Device Type <MLT>
Meter 1 <WN,1>
Meter 2 <---->
Meter 3 <---->
```

4. Select **Meter 1**. The following is displayed for the RGM:

```
Device Type <MTR>
Protocol <WN>
Device ID <1>
CT Rating <5A>
Meter Func. <Prod>
```

5. Verify:
- **Device Type** → **MTR**
 - **Protocol** → **WN**
 - **Device ID** → **1**
 - **CT Rating** → **5A**
 - **Meter Func.** → **Prod** (production)
6. Select **Meter 2** and configure the external meter settings:
- Select **Device Type** → **Revenue Meter**
 - Select **Protocol** → **WattNode**
 - Set **Device ID:** **2**
 - Set the CT rating to the value that appears on the CT: **CT Rating** → **<xxxxA>**. The default is 5 Amperes. If the displayed rating is 0 or you cannot change the value, there is no communication with the meter. Check that the AC power to the meter is on.
 - Select **Meter Func.** → **Export/Import/Export+Import/Consumption**

Verifying Meter Connection

1. Press the Enter button or the LCD external button until the Communication status screen is displayed as shown below. When two meters are connected, a screen similar to the following should appear:

```
Dev Prot ##
RS485-1<MLT><02><02>
RS485-2<----><----><---->
ZigBee <----><----><---->
```

Dev: The type of device configured to this port. **MLT** indicates multiple meters.

Prot: The number of configured meters.

: The number of communicating meters. For dual meters it should display 2. If not, refer to *Troubleshooting* below.

2. Press the Enter button or the LCD external button until reaching the Meter status screen showing the total energy [Wh]. There is a status screen for each meter function. For example, for an export+import meter and a production meter, there will be three status screens: for export, import and production. The following is an example of an export meter:

```
Export Meter
Status: <OK>
<Error Message>
Total [Wh]: XXXXXXXX
```

Status: Displays OK if the meter is communicating with the communication board.

<Error message>: If an internal meter error occurs, it will be displayed here. Refer to *Troubleshooting Meter Connection* on page 15.

Total [Wh]: The amount of Watts per hour of the designated meter.

If the SolarEdge device is connected to the SolarEdge server this value will also be displayed in the monitoring portal.

Troubleshooting Dual-meter Connection

Communication Status Screen Troubleshooting

When two meters are connected on the same RS485 bus, the following should appear in the Communication status screen:

```
Dev Prot ##
RS485-1 <MLT><02><02>
RS485-2 <---><---><--->
ZigBee <---><---><--->
```

Device Type or Protocol are configured incorrectly

If **MLT** (Multi) is not displayed as the device type (DEV), or **2** is not displayed as the number of meters under Prot (protocol), configure the meters as follows:

1. Select **Communication** → **RS485-x Conf** → **Device Type** → **Multi Devices**. Select **Device 1** or **Device 2**.
2. Select **Communication** → **RS485-x Conf** → **Protocol** → **WattNode**.
3. Select **Revenue Meter** → **Meter Func.** → **Production, Consumption, Export, Import, or Export+Import**.
4. Check that the Device ID under **Communication** → **RS485-x Conf** → **Device ID** is set to 1 or 2.

Number of devices is lower than configured or not displayed

If **<-->** or **<01>** is displayed under the **##** column in the Communication status screen shown above, at least one of the meters is not communicating with the inverter. Check the following:

- The meter configuration is as described above.
- There are no loose connections at the inverter connectors and at the meters, specifically the RS485 wiring.

Meter Status Screen Troubleshooting

Refer to *Meter Status Screen Troubleshooting* on page 15.

Appendix C: Meter Information Displayed in the Monitoring Portal

If your device is connected to the SolarEdge server, you can view the meter’s readings in the monitoring portal. Verify that the meter type is set correctly in the Admin page > Logical Layout > Meter details:

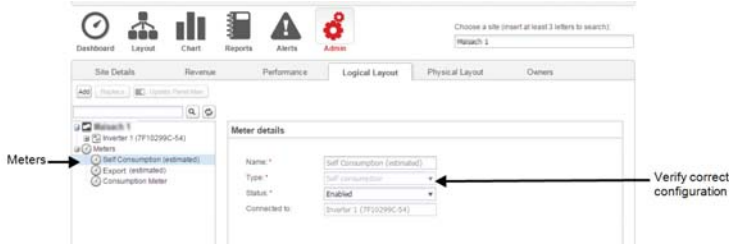

Figure 18: Setting the Meter details in the monitoring portal

Calculated meter readings (also referred to as "virtual meters"), such as self-consumption, are calculated using the data measured by the meter and the inverters.

The data from the inverters and from installed meters is displayed in the Dashboard and Charts tabs of the monitoring portal. The displayed data depends on the meter(s) location: grid connection point (export), or load consumption point (consumption). The following tables detail the displayed information per meter location.

Export meter:

Data	Displayed in Monitoring Dashboard	Displayed in Monitoring Charts
Production	✓	✓
Consumption	✓ (calculated)	✓ (calculated)
Self-consumption	✓ (calculated)	✓ (calculated)
Export	X	✓
Import	X	✓

Consumption meter:

Data	Displayed in Monitoring Dashboard	Displayed in Monitoring Charts	Displayed in Monitoring Dashboard	Displayed in Monitoring Charts
Production	✓	✓	✓	✓
Consumption	✓	✓	✓	✓
Self-consumption	✓ (calculated)	✓ (calculated)	✓ (calculated)	✓ (calculated)
Export	X	✓ (calculated)	X	✓ (calculated)
Import	X	X	X	X

Appendix D: Meter Technical Specifications

	SE-MTR240-2-200-S1	SE-MTR240-2-400-S1	UNITS
ELECTRICAL SERVICE			
Operating Voltage Range - Line to Line	211 - 264		Vac
AC Frequency	60		Hz
Grids Supported	L1 / L2 / N / PE		
Power Consumption (typ.)	1.2		W
COMMUNICATION			
Supported Communication Interfaces	RS485		
Response time	≤1		sec
Device ID (Modbus)	2		
ACCURACY (@ 77°F / 25°C, PF:0.7- 1)			
1% - 100% of Rated CT Current	±1		%
CURRENT TRANSFORMERS			
Rated RMS current ¹	200	400	
Dimensions (Internal ; External)	0.8 x 0.8 ; 2.4 x 2.4 / 20 x 20 ; 61 x 61	1.26 x 1.83 ; 3.3 x 4.5 / 32 x 46.5 ; 83.4 x 114	in/mm
STANDARD COMPLIANCE			
Safety	UL1741		
INSTALLATION SPECIFICATIONS			
Dimensions (HxWxD)	8.1 x 12.4 x 4.6 / 206.6 x 316 x 117.5		in / mm
Weight	3.9 / 1.8		lb / gm
Enclosure type	High impact, ABS and/or ABS/PC plastic UL 94V-0, IEC FV-0		
Operating Temperature Range	-22 to +131 / -30 to +55		°F / °C
Relative Humidity (noncondensing)	5 - 90		%
Protection Rating	NEMA Type 3R		
Conduit Entry Diameters	0.75 or 1/ 19 or 25		in / mm
Mounting Type	Wall mount		

¹For other ratings contact SolarEdge

Appendix E: External Lightning Protection Connection

Protection devices are most often installed from each data line to the local earth ground, and should be selected to begin conducting current at a voltage as close to the system's normal communication level as possible, but never lower. For RS485 communication lines, the selected voltage rating is typically 6-8 V. Transient suppressors should be installed as close as possible to the port that is being protected, and the user must provide an extremely low impedance connection to the local earth ground of the SolarEdge device. This ground connection is crucial for proper suppression device operation. The ground connection should be made using a heavy gauge wire and kept as short as possible. If the cable between the SolarEdge device and the protection device must be longer than 1m/ 3.3 ft., a copper strap or a braided cable intended for grounding purposes must be used for the protection device to be effective. In addition to the high frequency nature of transients, extremely high current may flow.

A protective device with surge discharge ratings of **In**: 10kA 8/20µs and **Imax**: 20kA 8/20µs is recommended.

Various lightning protection devices are available for RS485 communication lines.

The diagram below shows a connection example using the ISKRA ZAŠČITE VM-RS 485 data protocol protection device. A detailed datasheet can be found at: <http://iskrazascite.si/uploads/datasheet/1396000869.pdf>.

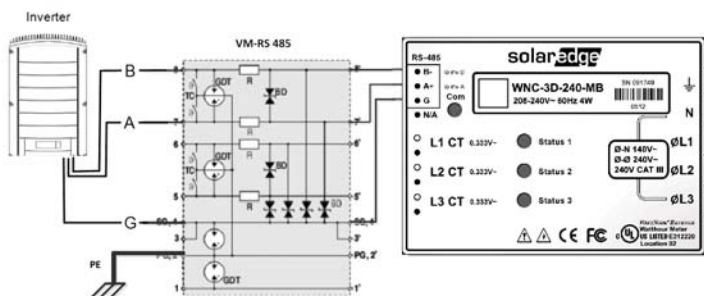

Figure 19: Protection connection

If you have technical queries concerning our products, please contact our support through SolarEdge service portal:

<http://www.solaredge.com/groups/support/services>

USA and Canada: + 1 (0) 510 498 3200
Worldwide: + 972 (0) 73 240 311 8
Fax: + 1 (0) 530 273 276 9
Email to: support@solaredge.us

www.solaredge.us

solaredge