

## Specifications

Device	Combiner	RSI	BKR-CTRL-DC	RTB
Voltage	600 Vdc	24 Vdc ± 3%	N/A	300 Vdc/pole
Total Current	96 Adc	N/A	N/A	75 Adc/pole
DC Input	24 Vdc ± 3%	24 Vdc ± 3%	24, 32, 36, 48 Vdc (battery nominal)	From BKR-CTRL-DC
Compatibility	Up to 6 PV input strings per combiner	Controls up to 6 combiner boxes and 2 relay-trip breakers	Powers up to 6 combiner boxes and 2 relay-trip breakers	Up to 4 poles 1 pole: PNL-75-DC-RT 2 poles: PNL-75D-DC-RT 4 poles: PNL-75Q-DC-RT
Overcurrent Protection	(6) 600 Vdc DIN rail fuse holders	N/A	3AG Cartridge, 3A slow-blow, 10kA@125VDC	N/A
Power Draw	0.10 Adc	0.06 Adc	0.05 Adc	N/A
Enclosure Rating	UL Type 3R	UL Type 3R	UL Type 1 with connector enclosure	UL Open Type
Ambient Temp.	-25 to 60°C	-25 to 60°C	-25 to 50°C	-25 to 50°C
LED indicators	Arc Fault	SOLAR ON SOLAR OFF AFCI	N/A	N/A
Knockouts	2", ½", ¾"	½"	N/A	N/A

## Dimensions

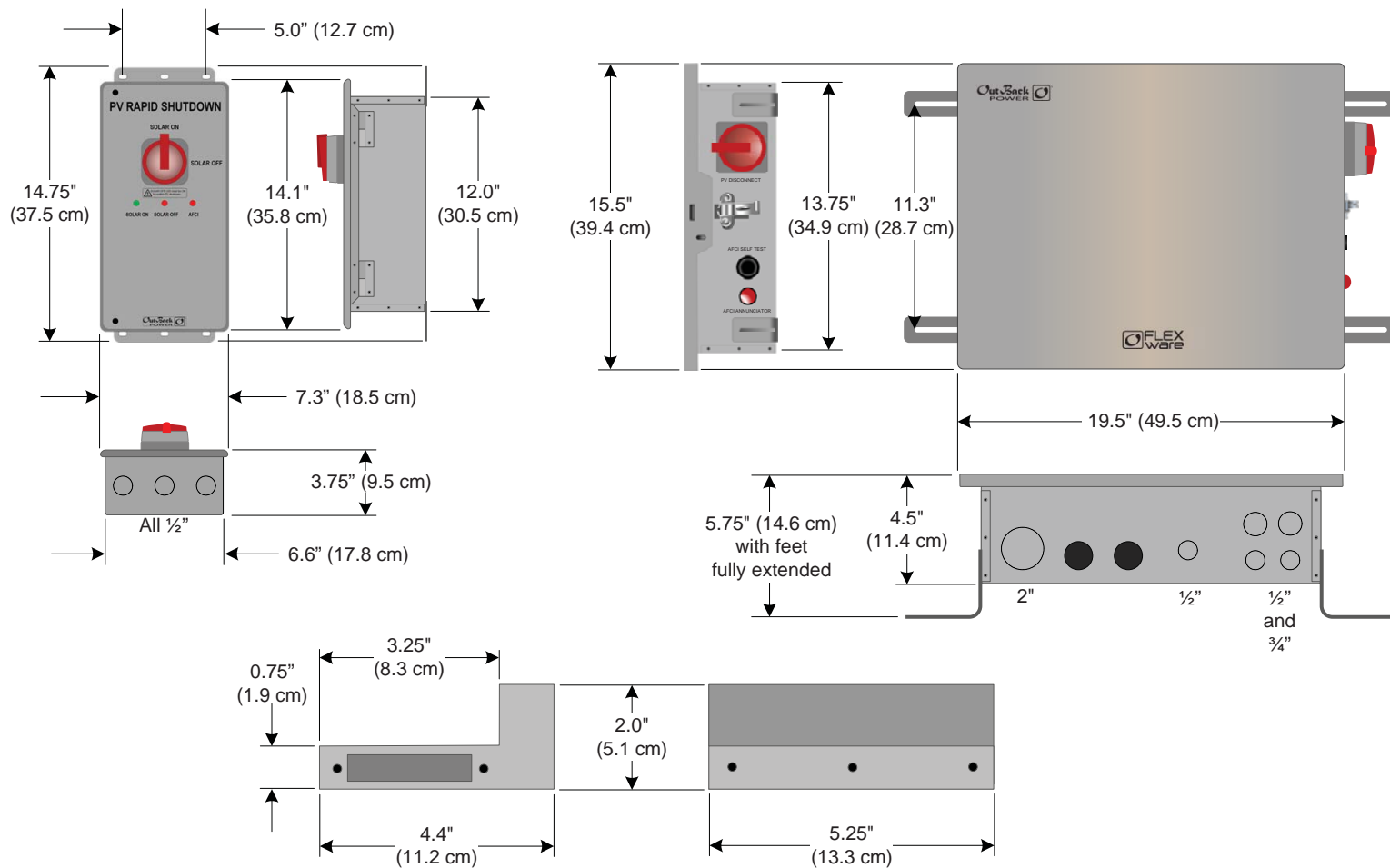

## Listings

- UL1741
  - including PVRSS
- UL1699/UL1699B
- CSA C22.2
  - including PVRSS

## Compliance

- FCC Part 15, Class B

### NOTES:

- ❖ The DC input and output circuits are isolated from the enclosure.
- ❖ The photovoltaic system grounding shall be installed according to the requirements of Sections 690.41 through 690.47 of the National Electric Code (ANSI/NFPA 70). The installer is responsible for all system grounding.
- ❖ Use only UL514B-compliant wet location or rain-tight conduit hubs for entry into the enclosure.

# FLEXware™ Integrated Combiner Solution Plus

## Features:

- First end-to-end solution listed to UL1741 with PV rapid shutdown systems (PVRSS)
- Arc fault circuit interrupter (AFCI) listed to UL1699B with local and remote indication
- Type 3R enclosures rated for indoor or outdoor installation
- Flexible design — install the combiner box vertically or horizontally and mount to racking or under an array
- Interoperability with compatible third-party PV rapid shutdown devices (PVRSE with dry contact)

## Components Included:

- ICS Plus Combiner Box
  - FWPV6-FH600-SDA (1)
- Rapid Shutdown Initiator Box
  - RSI (2)
- Circuit Breaker Control Box
  - BKR-CTRL-DC (3)
- Relay-Trip Breaker (RTB) Device
  - PNL-75-DC-RT (4)
  - PNL-75D-DC-RT (5)
  - PNL-75Q-DC-RT (6)

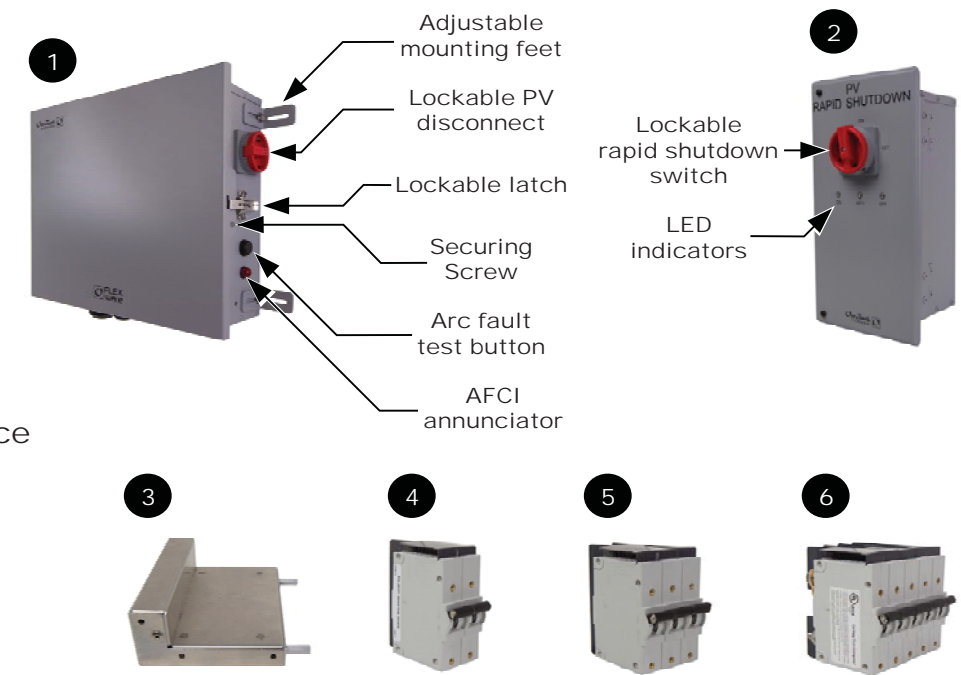

## Packages Available:

NOTE: All packages include (1) RSI, (1) BKR-CTRL-DC, (1) RTB device, and (1) or more FWPV6-FH600-SDA combiner boxes. All packages are equipped with rapid shutdown, external disconnect, and PV AFCI functions.

- ICSPLUS-1: Compatible with up to 6 strings of PV (one charge controller); includes (1) FWPV6-FH600-SDA
- ICSPLUS-2: Compatible with up to 12 strings of PV (two charge controllers); includes (2) FWPV6-FH600-SDA
- ICSPLUS-4: Compatible with up to 24 strings of PV (four charge controllers); includes (4) FWPV6-FH600-SDA

## Accessories Available:

- Box of (10) 15A Fuses
  - FUSE-15-600VDC
- Box of (10) 20A Fuses
  - FUSE-20-600VDC
- 30A, 1000 Vdc Fuse Holder
  - FH-30-1000VDC-DIN
- PV Rapid Shutdown Label
  - LBL-PVRSS

# Installation (SAVE THESE INSTRUCTIONS)

This document contains important instructions that shall be followed during installation and maintenance of the power system.

## Mounting:

NOTE: The surface and fastening hardware must be able to support the weight of all products.

- Remove any necessary knockouts.
- Mount the RSI box using the holes located in the mounting brackets. (See C.)
  - Secure the RSI appropriately for the mounting type.
  - The RSI box should be installed near the service meter. It must be mounted vertically and must be at least 36" (91.4 cm) above the ground.
- Mount the combiner box using the four mounting feet. During shipping, these feet are attached facing inward. They should usually be repositioned facing outward for mounting as shown in D. The feet are slotted for exact spacing requirements in differing locations.
  - Secure the combiner appropriately for the mounting type.
  - The combiner box can be mounted horizontally, vertically, or at any intermediate angle. It must be mounted at least 36" (91.4 cm) above the ground. See E.
  - To meet PVRSS requirements, mount the combiner within 10' (3m) of the PV array.
- Mount the Circuit Breaker Control box, BKR-CTRL-DC. Different options are available with different load centers.
  - FLEXware 500 or 1000:** Install it in one circuit breaker slot in the DC enclosure.
  - FLEXware 250:** This box is not installed inside the enclosure. It is installed externally using the included bracket F, alongside the FLEXnet DC Battery Monitor. See G.
  - GSLC:** Install it in one circuit breaker slot on the DC rail. See B and the NOTES below.
  - If necessary, the slotted holes on this bracket allow it to be installed in various external locations on the GSLC or the Radian inverter.
- Install the Relay-Trip Breaker (RTB) in the load center. See A.
  - Each RTB takes the place of a PV input circuit breaker. Note that each RTB assembly requires an additional circuit breaker slot.

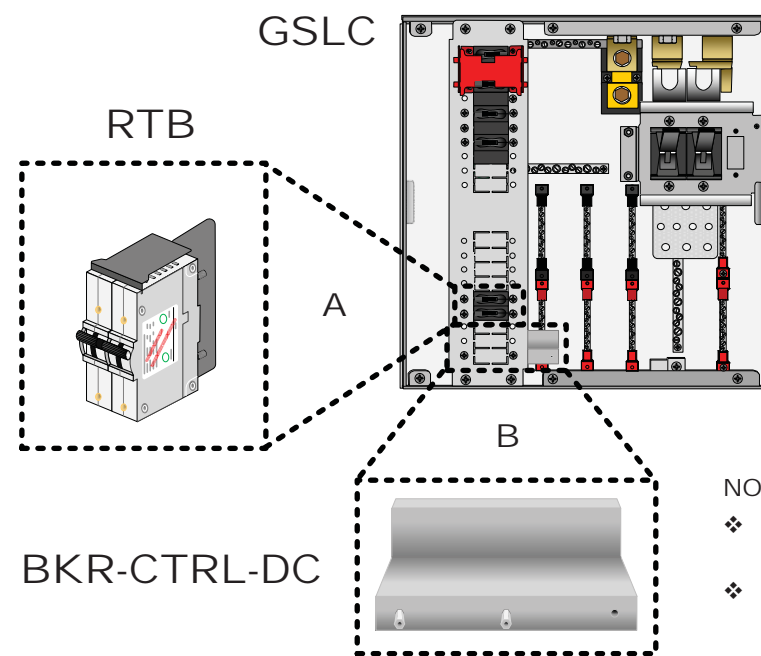
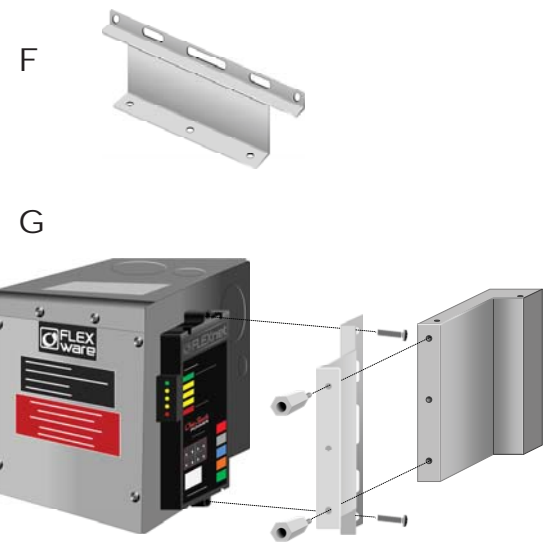
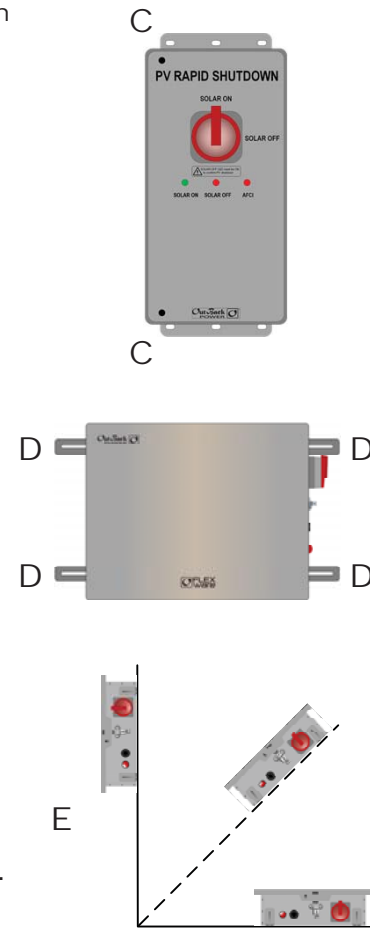

### NOTES for B:

- ❖ Two hexagonal standoffs must be installed on the BKR-CTRL-DC to allow it to fit behind the rail.
- ❖ The standoffs can be installed in either the two right-hand or the two left-hand holes (as shown in B). This allows either of two mounting positions.
- ❖ Secure the BKR-CTRL-DC on the rail by attaching two screws to the standoffs.

# Wiring

## Wiring:

NOTE: These instructions assume the use of one combiner, one RTB, the RSI, BKR-CTRL-DC, and a battery source. For applications with a different combination of items, see the second sheet. (The load center must be installed according to the appropriate instructions.)

- Ensure all electrical sources to the system are disconnected (both PV and batteries).
- Wire all system components as noted below. See the illustration to the right for BKR-CTRL-DC pin order. See the next sheet for wiring illustrations. Note that battery cabling and load center internal wiring are not depicted.

- Connect BKR-CTRL-DC pins 1 and 2 to the DC bus bars in the load center. Pin 1 connects to the negative (-) and pin 2 to the positive (+).

NOTE: The positive (+) wire must be protected with the following fuse type:  
3AG Cartridge, 3A slow-blow, 10kA@125VDC

- Connect BKR-CTRL-DC pins 3 and 4 (24 Vdc supply) to the red (pin 4) and black (pin 3) terminals on the RSI port labeled J1. See Caution below.
- Connect the red and black terminals on the RSI port labeled J2 (24 Vdc supply) to the red and black terminals on the combiner port labeled J1.
- Connect BKR-CTRL-DC pins 5 and 6 (breaker trip status) to the white and green terminals on the RSI J1 port.
- Connect the green and white terminals on the RSI J2 port (arc fault status) to the white and green terminals on the combiner J1 port.
- Connect BKR-CTRL-DC pins 7 and 8 to the RTB trip sensing screws.
- Connect BKR-CTRL-DC pins 9 and 10 to the RTB breaker-trip coil wires.
- Connect the PV array positive (+), negative (-) and ground to the combiner fuse holders and terminal bus bars (TBB).

NOTE: PV input wiring must be outdoor rated. It must be suitable for both wet locations and UV exposure.

- Connect the combiner positive (+), negative (-) and ground to the load center bus bars. Connect the RSI ground to the load center ground bar.
- Connect the RTB and charge controller PV terminals to each other and to the load center bus bars. (See charge controller literature for specific connections.)

- Tighten all connections to the torque values on the table below.
- Connect PV and other sources. Apply power to the system as appropriate.

**CAUTION: EQUIPMENT DAMAGE**  
The 24-volt negative conductor is not grounded and is not to be connected to chassis or any other grounding system.

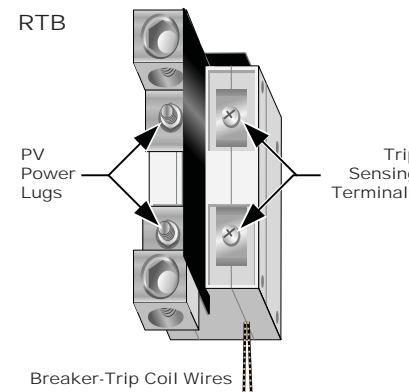
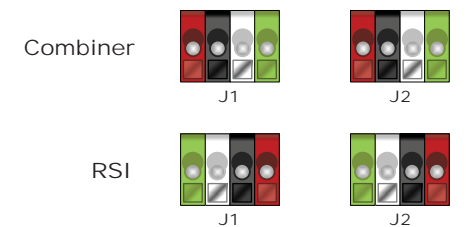
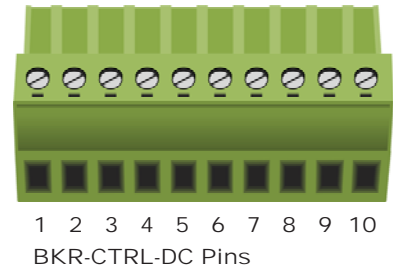

## Torque Requirements by Wire Size (copper conductors only)

Cable Size*	Negative (-) Combiner TBB (large holes)	Negative (-) Combiner TBB (small holes)	Ground TBB	Ground Lug (combiner)	Ground Stud (BKR-CTRL-DC)	Contactors Terminal	RTB Compression Lugs (5/32 hex)
2/0 AWG (70 mm <sup>2</sup> )	50 in-lb (5.7 Nm)	—	—	—	—	50 in-lb (5.7 Nm)	50 in-lb (5.7 Nm)
1/0 to #1 AWG (50 mm <sup>2</sup> )	50 in-lb (5.7 Nm)	—	—	50 in-lb (5.7 Nm)	—	50 in-lb (5.7 Nm)	50 in-lb (5.7 Nm)
#2 to #3 AWG (35 mm <sup>2</sup> )	50 in-lb (5.7 Nm)	—	—	50 in-lb (5.7 Nm)	50 in-lb (5.7 Nm)	50 in-lb (5.7 Nm)	50 in-lb (5.7 Nm)
#4 AWG (25 mm <sup>2</sup> )	45 in-lb (5.1 Nm)	—	35 in-lb (4.0 Nm)	45 in-lb (5.1 Nm)	50 in-lb (5.7 Nm)	45 in-lb (5.1 Nm)	40 in-lb (4.5 Nm)
#6 AWG (16 mm <sup>2</sup> )	45 in-lb (5.1 Nm)	—	35 in-lb (4.0 Nm)	45 in-lb (5.1 Nm)	40 in-lb (4.5 Nm)	45 in-lb (5.1 Nm)	40 in-lb (4.5 Nm)
#8 AWG (10 mm <sup>2</sup> )	40 in-lb (4.5 Nm)	25 in-lb (2.8 Nm)	25 in-lb (2.8 Nm)	40 in-lb (4.5 Nm)	40 in-lb (4.5 Nm)	40 in-lb (4.5 Nm)	40 in-lb (4.5 Nm)
#10 AWG (6 mm <sup>2</sup> )	35 in-lb (4.0 Nm)	20 in-lb (2.3 Nm)	20 in-lb (2.3 Nm)	35 in-lb (4.0 Nm)	40 in-lb (4.5 Nm)	35 in-lb (4.0 Nm)	40 in-lb (4.5 Nm)
#14 to #12 AWG (2.5 to 4 mm <sup>2</sup> )	35 in-lb (4.0 Nm)	20 in-lb (2.3 Nm)	20 in-lb (2.3 Nm)	35 in-lb (4.0 Nm)	15 in-lb (1.7 Nm)	35 in-lb (4.0 Nm)	15 in-lb (1.7 Nm)

NOTES: The RTB trip-sensing screws and the BKR-CTRL-DC ground stud are 10-32 size and use a torque value of 15 to 20 in-lb (1.7 to 2.3 Nm). The RTB lugs (under the compression lugs) are 1/4-20 size and use a torque value of 30 to 35 in-lb (3.4 to 4.0 Nm). The BKR-CTRL-DC connector screws receive #12 to #26 AWG wire and use a torque value of 4.4 to 5.3 in-lb (0.5 to 0.6 Nm). Minimum rating for all wires is 90°C. The exception is for PV source circuits above 50°C, which require wire rated for 105°C to avoid derating.

## Other Wire Sizes

Connection	Minimum*	Maximum*
Combiner Fuse Holder	#14 AWG (2.5 mm <sup>2</sup> )	#8 AWG (25 mm <sup>2</sup> )
BKR-CTRL-DC Fuse Holder	#18 AWG (1.0 mm <sup>2</sup> )	—
Communication Connectors	#22 AWG (0.5 mm <sup>2</sup> )	#16 AWG (1.5 mm <sup>2</sup> )

Connection	Minimum*	Maximum*
BKR-CTRL-DC Connector	#26 AWG (0.25 mm <sup>2</sup> )	#12 AWG (4 mm <sup>2</sup> )
PV Input Glands	—	Up to 7.7 mm diameter

\*AWG size conversions are listed to the closest equivalent mm<sup>2</sup> commercial size.

# Installation

# Wiring Drawing

**IMPORTANT: Example only.** This illustration depicts a negatively-grounded system. Actual wiring may vary. All configurations must comply with local and national electric codes. Consult local electric authorities to ensure compliance.

**NOTE:** This example shows a system with three PV subarrays, one combiner, a single-pole RTB, and the GS Load Center. The GSLC battery connections are not depicted, but are required.

### Communications Wire Length

Wire Size	Length
#16 AWG	200'
#18 AWG	125'
#20 AWG	80'
#22 AWG	50'

**NOTE:** These are the maximum allowed lengths are for the entire run of communications wire, including between additional combiners and other devices.

### Photovoltaic (PV) Array

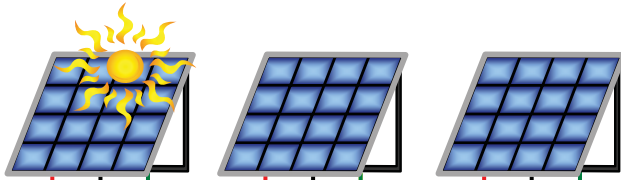

### Combiner

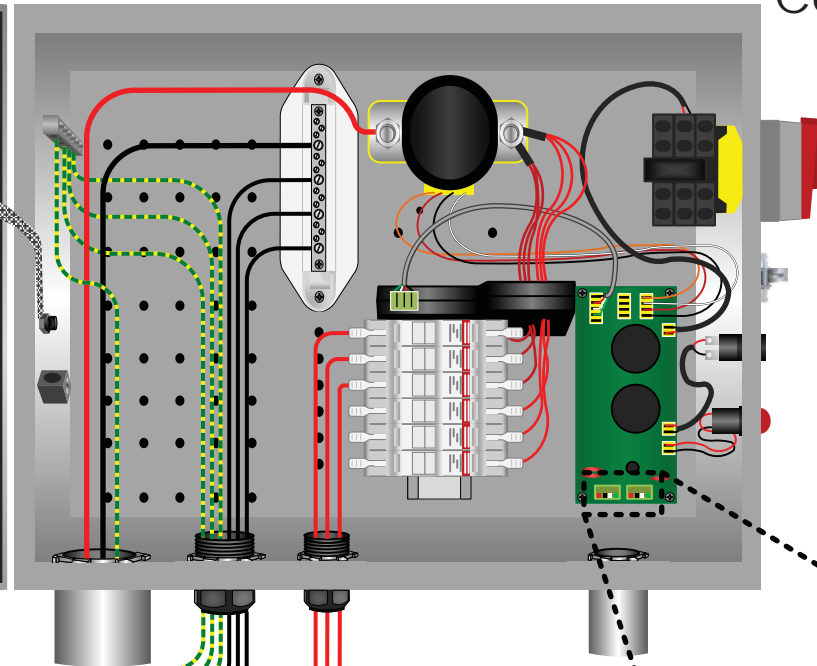

**IMPORTANT:** This jumper is required for correct operation.

**NOTE:** These wires may be routed through the PV conduit as long as they are rated for the maximum PV voltage.

### Charge Controller



### GSLC

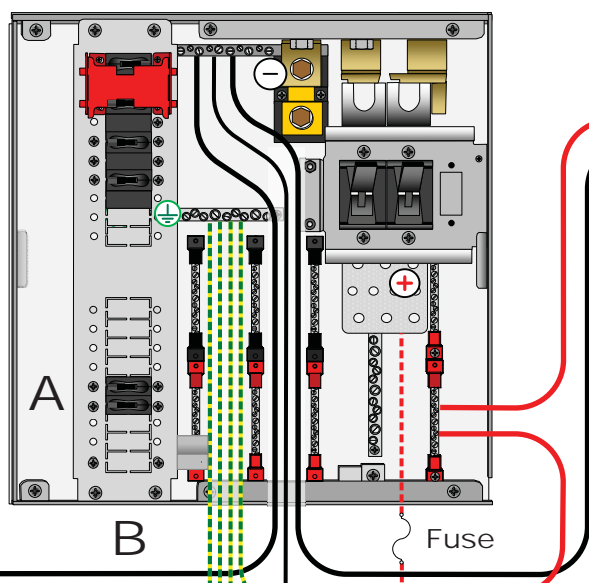

### BKR-CTRL-DC (B)

**NOTE:** Insert individual wires into the back of the plug. Secure them with a flat screwdriver. When mounting external to the load center, use the connector enclosure to ensure UL Type 1 compliance.

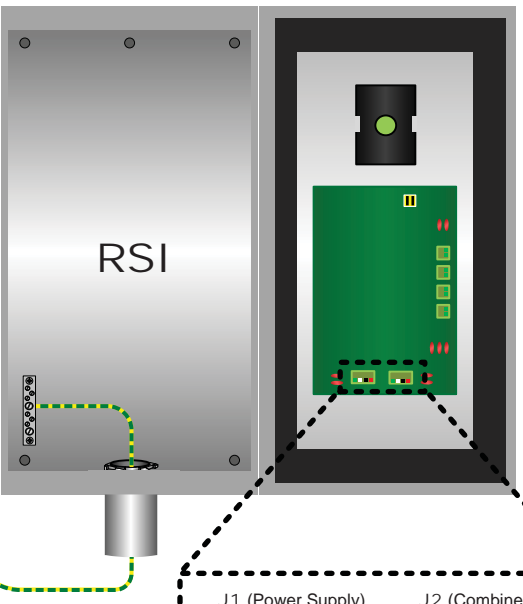

**NOTE:** Insert individual wires into each circular hole. Press on the slot with a narrow tool to unlock each opening.

DC LEGEND		
PV Negative (-)	⊖	Black
PV Positive (+)	⊕	Red
Ground	⊕	Green/White
24V RSI Supply Positive (+)		Red/Black
24V RSI Supply Negative (-)		Black/Black
24V Combiner Supply Positive (+)		Red/Black
24V Combiner Supply Negative (-)		Black/Black
PV Arc Fault		Green/White
PV RSI Safe		Black/Black
Breaker RSI Safe		Green/White
Breaker Trip		Black/Black
Trip Sense Contact (x2)		Orange/Black
Breaker Trip Coil (x2)		Black/Black

### RTB (A)



Ground Electrode Conductor

## Multiple Combiners

Up to six combiners can be used with a single Rapid Shutdown Initiator. The RSI can be used as an emergency shutoff for all of the six systems. Also, if any of the arrays suffer an arc fault, the RSI arc fault indicator will show that the fault has occurred. Six combiners can be powered by a single BKR-CTRL-DC.

Connect the control wires of additional combiners in series with the first combiner (designated 1 below). The J1 terminals for 1 are connected to the RSI as shown on the previous page. The J2 terminals are connected to the J1 terminals on 2. The J2 terminals on 2 are connected to the J1 terminals on 3 if present, and so on.

NOTE: J1 and J2 are interchangeable in the combiner and can be reversed if necessary. (See the connections between 4 and 5 below.) This statement is only true for combiner boxes.

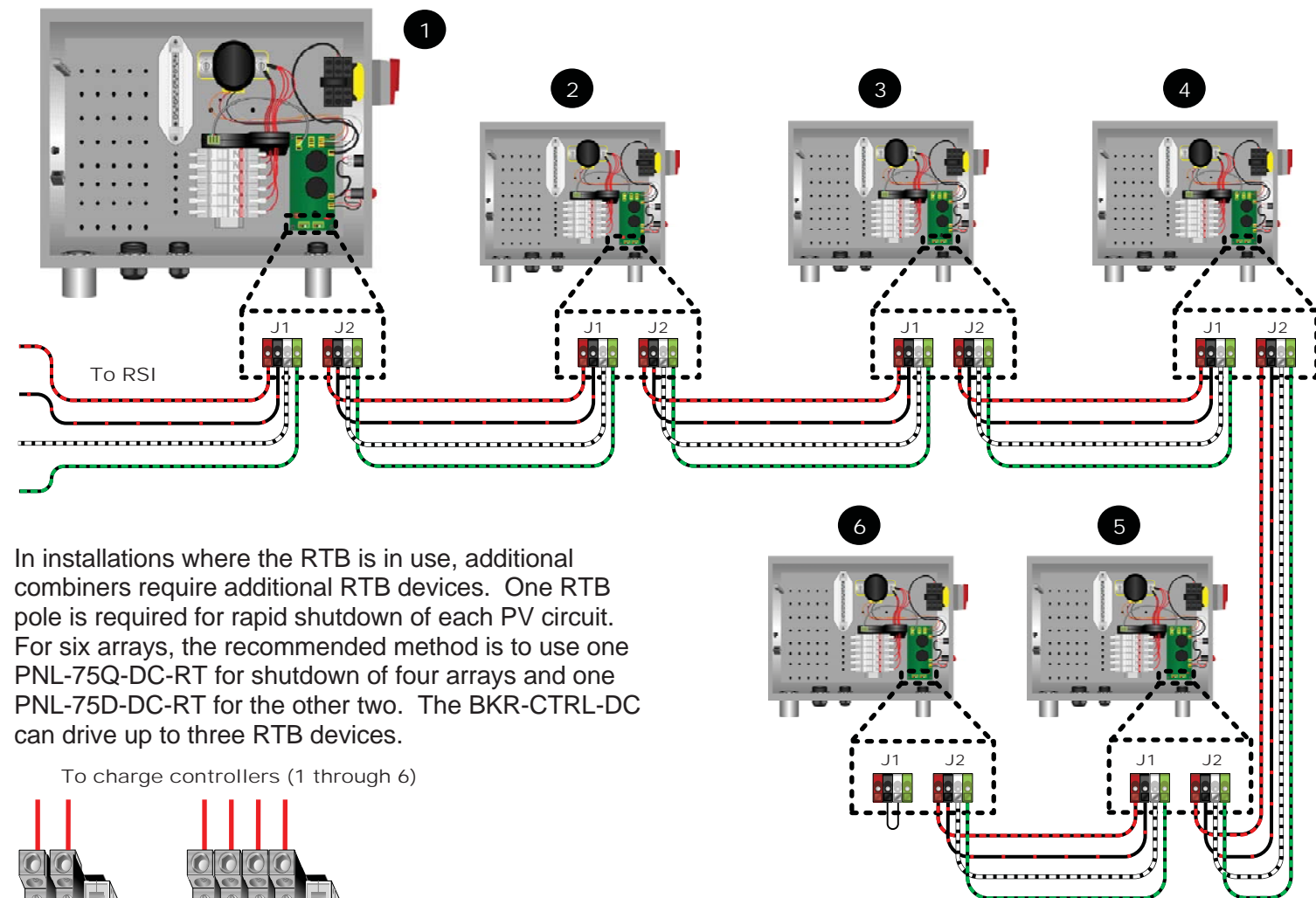

In installations where the RTB is in use, additional combiners require additional RTB devices. One RTB pole is required for rapid shutdown of each PV circuit. For six arrays, the recommended method is to use one PNL-75Q-DC-RT for shutdown of four arrays and one PNL-75D-DC-RT for the other two. The BKR-CTRL-DC can drive up to three RTB devices.

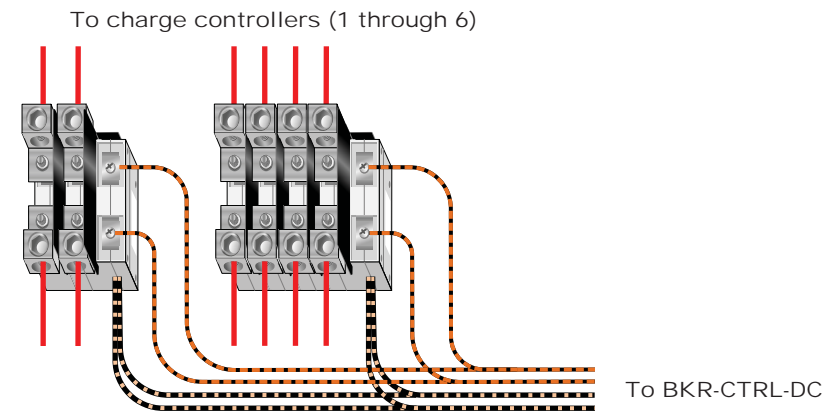

**IMPORTANT:**  
Install the jumper on the last combiner in the series. This jumper is required for correct operation.

## Other Applications

In systems where other system elements are required, the ICS Plus can be used with third-party equipment. Some systems may only need certain ICS Plus components, rather than the entire system. This may depend on the applicable code requirements.

Other applications not depicted here include:

- PV equipment with voltages in excess of 300 Vdc
- No requirement for PVRSS
- Non-battery-based systems
- Positive-grounded systems

See the *ICS Plus Owner's Manual* for more details on these specialized systems.

The instructions in this document assume a negative-grounded system, the use of a battery bank with 18 to 68 Vdc available (a 24/48-volt nominal bank) and the use of BKR-CTRL-DC, the Circuit Breaker Control Box. An isolated Class 2 DC power supply with the following specifications must be installed if BKR-CTRL-DC is not in use:

- 24 Vdc  $\pm$  3% maximum over input voltage, ambient temperature, output load, and initial accuracy
- Up to 1.5 Adc

This requirement may apply under the following conditions:

- Non-battery-based systems
- Battery-based systems with a different battery voltage than that stated above.

## Surge Protector

An optional surge protection device can be installed in the combiner. A knockout has been provided to accommodate this type of device. This image shows the underside of the combiner and the location of the knockout.

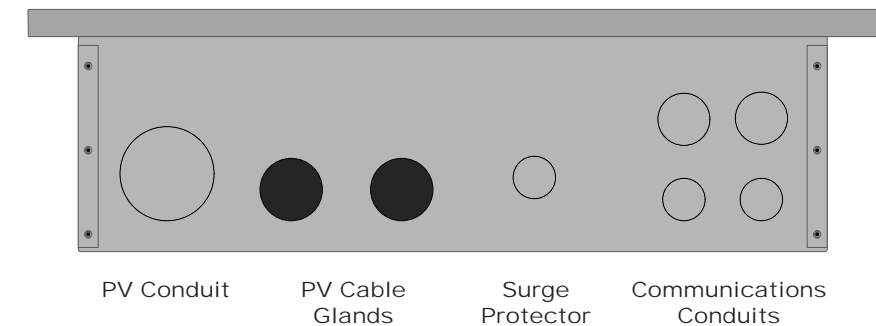

NOTE: Any installed devices must be liquid-tight to sustain the combiner's environmental rating.

## Contact Information

OutBack Power Technologies  
17825 – 59<sup>th</sup> Avenue NE  
Suite B  
Arlington, WA 98223

Telephone: +1.360.435-6030  
+1.360.618-4363 (Tech Support)  
+1.360.435.6019 (Fax)  
Email: Support@outbackpower.com  
Website: www.outbackpower.com

## Date and Revision

June 2016, Revision A