



ME-MR

Inverter Remote Control



Owner's Manual
(for Revision 1.0 or higher)

Disclaimer of Liability

Since the use of this manual and the conditions or methods of installation, operation, use and maintenance of the ME-MR are beyond the control of Magnum Energy Inc., this company does not assume responsibility and expressly disclaims liability for loss, damage or expense, whether direct, indirect, consequential or incidental, arising out of or anyway connected with such installation, operation, use, or maintenance.

Due to continuous improvements and product updates, the images shown in this manual may not exactly match the unit purchased.

Restrictions on Use

The ME-MR remote shall not be used in connection with life support systems, life saving or other medical equipment or devices. Using the ME-MR with this particular equipment is at your own risk.

Important Product Safety Instructions

This manual contains important safety instructions that must be followed during the installation and operation of this product. Read all instructions and safety information contained in this manual before installing or using this product.

- All electrical work must be performed in accordance with local, state and federal electrical codes.
- This product is designed for indoor / compartment installation. It must not be exposed to rain, snow, moisture or liquids of any type.
- Use insulated tools to reduce the chance of electrical shock or accidental short circuits.
- Remove all jewelry such as rings, watches, bracelets, etc., when installing or performing maintenance on the inverter.

Safety Symbols

To reduce the risk of electrical shock, fire, or other safety hazard, the following safety symbols have been placed throughout this manual to indicate dangerous and important safety instructions.



WARNING: This symbol indicates that failure to take a specified action could result in physical harm to the user.



CAUTION: This symbol indicates that failure to take a specified action could result in damage to the equipment.



Info: This symbol indicates information that emphasizes or supplements important points of the main text.



Remedy: This symbol provides possible solutions for related issues.

Table of Contents

1.0 Overview	2
2.0 Installation.....	3
3.0 Setup	6
4.0 Menu Map: ME-MR Remote Control	18
5.0 Operation	19
6.0 Troubleshooting	34
7.0 Limited Warranty	37

Table of Tables

Table 3.1, Battery AmpHrs to Absorb Charging Time	9
Table 3.2, Battery Size to Battery Amp-Hours (estimated)	10
Table 3.3, Battery Type to Charge Voltages	11
Table 3.4, Inverter/Charger Default Settings	17
Table 5.1, LED Indicator Guide	33
Table 6.1, Remote Troubleshooting	34

List of Figures

Figure 1-1, Front Panel Features	2
Figure 2-3, Remote Control Connections	5
Figure 4-1, Inverter/Charger Menu Map.....	18
Figure 6-1, Performing an Inverter Reset.....	36

Introduction

1.0 Overview

The ME-MR remote control allows you to monitor and customize basic operating parameters to your Magnum inverter/charger. The ME-MR remote can be used on all Magnum inverter/charger models.



INFO: The ME-MR remote control has minimal settings available in the Setup Menu. Careful consideration should be given to choosing this remote over the full featured ME-RC when customizing the inverter/charger for your particular system.

The ME-MR25 comes standard with a 25 foot, 4-conductor telephone cable and includes non-volatile memory (preserves adjustable settings, even if power to the remote or inverter is removed).

This manual is for the ME-MR with revision 1.0 or higher; see the *TECH: 02 Revisions* display on page 16 for information on how to determine your revision level.

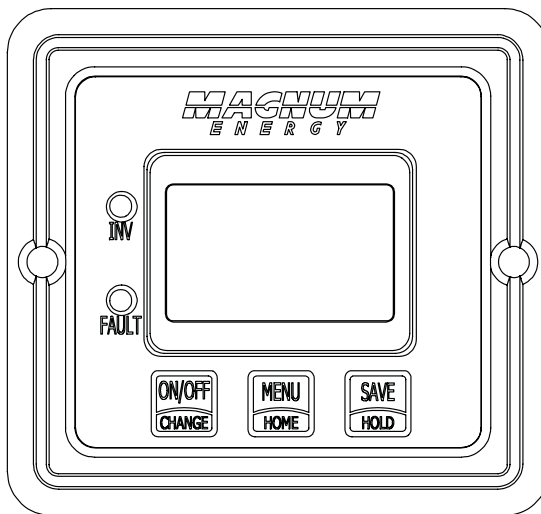

Figure 1-1, Front Panel Features

The ME-MR is equipped with the following features:

- **LED Indicators** - at-a-glance LEDs provide the inverter/charger status in a straightforward way.
- **LCD Display** - is a 8 x 2 line (16 characters total), alphanumeric display, used for setting up the inverter/charger operation as well as viewing current status or fault messages.
- **ON/OFF or CHANGE Pushbutton** - allows the inverter to be turned On and Off. The "ON/OFF" button also serves as a "CHANGE" button when navigating through SETUP and TECH menus.
- **MENU or HOME Pushbutton** - accesses SETUP and TECH menus. The "MENU/HOME" button also serves as a "HOME" button to return directly to the "Status" menu
- **SAVE or HOLD Pushbutton** - button serves as a "SAVE" button to save settings when in the SETUP menus The "HOLD" button stops the status screen scrolling.

2.0 Installation

Before installing the remote, read the entire installation section to determine how you are going to install your ME-MR. A thoroughly planned system is much more likely to meet your inverter system needs.



Info: Installations should be performed by qualified personnel, such as a licensed or certified electrician. It is the installer's responsibility to determine which safety codes apply and to ensure that all applicable installation requirements are followed. Applicable installation codes vary depending on the specific location and application.



Info: Review the "Important Product Safety Information" on the front inside cover page before any installation.

- Before connecting any wires, determine the remote cable route throughout the home or vehicle/boat both to and from the inverter.
- Always check for existing electrical, plumbing or other areas of potential damage before drilling or cutting into walls to mount the remote.
- Make sure all wires have a smooth bend radius and do not become kinked.
- If installing this remote in an boat, RV or truck; ensure the conductors passing through walls, bulkheads or other structural members are protected to minimize insulation damage such as chafing, which can be caused by vibration or constant rubbing.

Installing the remote control is a simple process and requires the following tools:

- Phillips screwdriver
- Level
- Drill Motor
- Cut-out tool (knife/saw)
- Pencil
- Drill Bit (7/64")

2.1 Installation Procedure

Select an appropriate location to install the remote control. Allow ample room to access the remote's buttons and to view the LEDs. Ensure the viewing angle of the display is appropriate.

1. Refer to figure 2-1 for flush mount hole cutout dimensions.
2. Refer to figure 2-2 for Surface Mount Bezel dimensions.
3. Run the remote cable between the remote and the inverter/charger. This cable is a 4-wire telephony standard with RJ11 connectors on each end. A standard telephone cable may be substituted if the provided remote cable is not able to be used.
4. Connect the remote cable into the RJ11 "Remote" port (has blue label) on the inverter/charger (see figure 2-3).
5. Have the inverter connected to batteries, but ensure the inverter is off and that no AC power is connected to the inverter.
6. While monitoring the front of the remote, connect the other end of the cable into the RJ11 jack on the back-side of the remote (see figure 2-3).

Setup

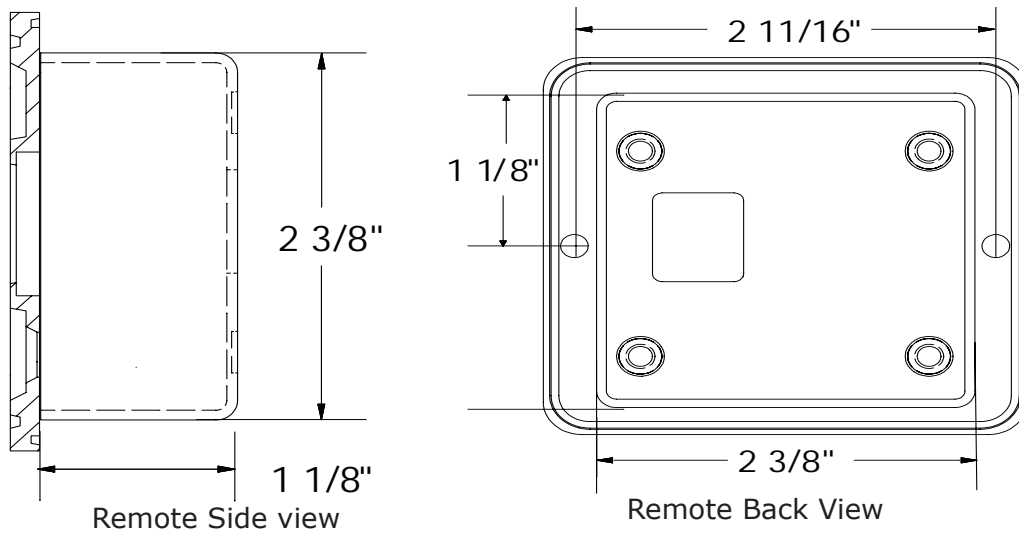

Figure 2-1, Flush Mount Remote Cut-Out Dimensions

After selecting the desired location for Flush mounting the remote cutout a mounting hole measuring $2 \frac{3}{8}'' \times 2 \frac{3}{8}''$. Mount the remote into the cutout and use the remote to mark and predrill 2 holes for the $6 \times \frac{1}{2}''$ phillips flat head mounting screws.

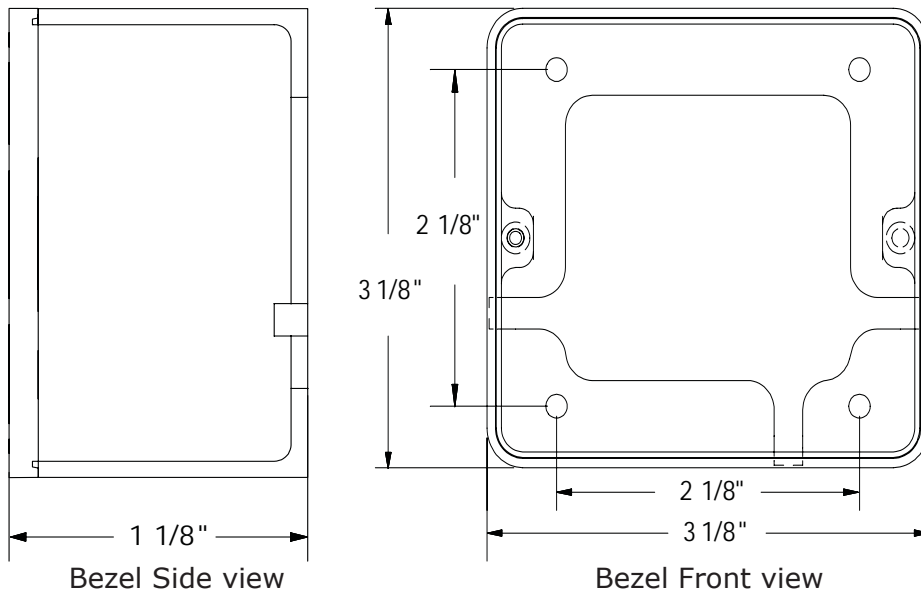

Figure 2-2, Surface Mount Bezel Dimensions

After selecting the desired location for the Surface Mount Bezel mount the Bezel using the Bezel as a template. Mark and predrill $4 \frac{1}{8}''$ holes. Mount the Bezel using the four $\#6 \times \frac{3}{4}''$ screws. Next mount the remote to the Bezel using the two $\#6 \times \frac{1}{2}''$ Phillips flat head screws.

7. Immediately upon connecting the remote cable, all the LED's will come on as the unit goes through a self-test. After the initial self-test completes, text should appear with a system status message indicating the current state of the inverter/charger. If not, please refer to the troubleshooting section.
8. The remote is ready for setup.



Info: All power to operate the remote control is provided by the inverter/charger through the remote cable

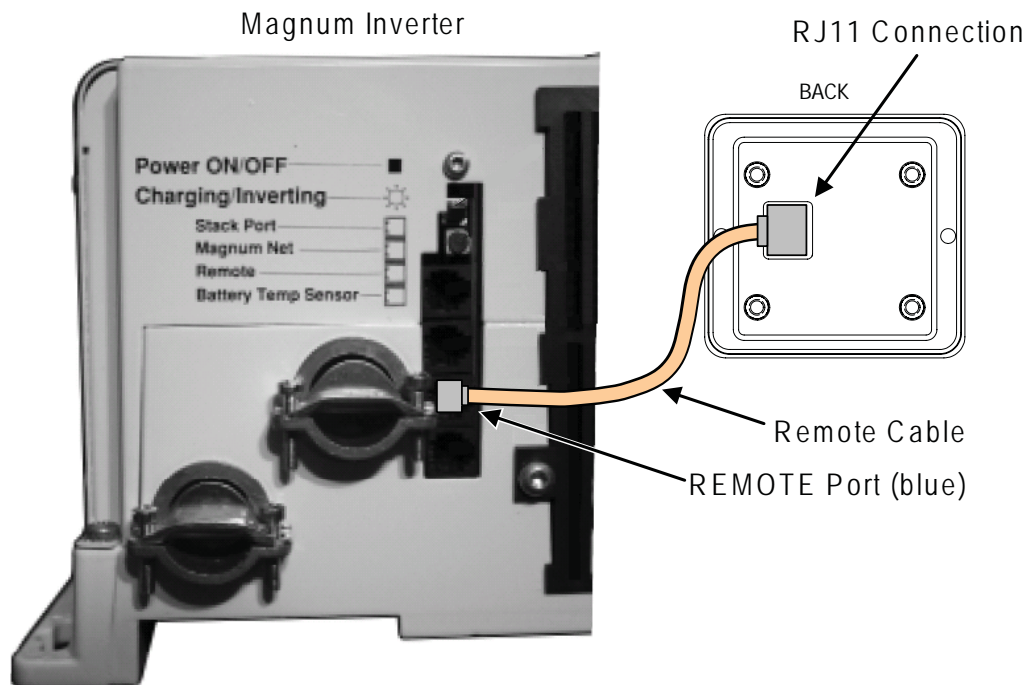

Figure 2-3, Remote Control Connections

Setup

3.0 Setup

When the remote is connected to a Magnum inverter/charger, the settings in the remote control determine the inverter/charger operating parameters. The default settings in the remote control (see Table 3-4, Inverter/Charger Default Settings) are adequate for most installations, however you have the option to change some of the operating parameters if required. This section will show you how to navigate the remote, give you an understanding of the function of each adjustable setting and help you decide what setting should be used.

3.1 Navigating the Remote's Menu

The ME-MR has an internal structure that provides menu items and adjustable settings that provide the ability to configure your inverter/charger to your specific parameters.



Info: See figure 4-1, *Inverter/Charger Menu Map* for a complete map of the inverter/charger menu items and adjustable settings.

Familiarize yourself with the items on the front panel which are used to find, adjust and save the desired setting. They are:

- **LCD Display** - The bottom line of the LCD display shows the menu items, adjustable settings or the meters display information.



Info: The bottom line of the LCD display returns to the Home Screen to show DC voltage and current (see *Figure 3-1*) after 30 Seconds - if no buttons have been pressed.



Info: When the "←" (left facing arrow) symbol is shown on the display, it indicates that the displayed setting has been selected and will be used.

- **Menu Pushbutton** - Allows simple access to the menu items that can help with configuring, monitoring and troubleshooting your inverter/charger system.
- **Change Pushbutton** - This button allows you to quickly scroll through and select various menu items and settings after pressing the menu pushbutton.
- **Save Pushbutton** - This button saves the menu item displayed on the screen. A saved setting is indicated by arrow symbol.

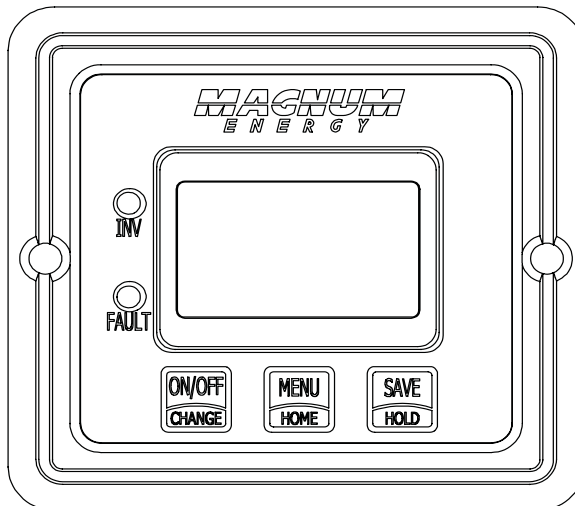

3.2 Menu Pushbuttons and Menu Items

Read this section to help understand the function of each menu pushbutton and the configurable settings - to determine if they should be changed to optimize the operation of the inverter/charger.

This menu pushbutton gives a quick means of changing your Shore setting to coordinate with the circuit breaker rating from the incoming AC source.

- **SETUP: 01 SHORE** - This selection ensures the inverter AC loads receive the maximum current available from the utility or generator power. Whenever the utility or generator is connected to the inverter (thru AC HOT 1), the current used to power the AC loads and to charge the batteries is monitored. When the total current used to power the AC loads and charge the batteries begins to approach the *Shore* setting, the current that was used for charging the batteries will automatically be reduced. This ensures the AC loads have all the available current when needed. The feature is not available on the MM and MMS inverter/chargers.

Default setting: Shore Max = 30A

Where to set: Set the *Shore* setting to match the current rating of the utility power or generator's circuit breaker. If using multiple AC sources (utility and generator) through an AC transfer switch, adjust this setting to the smaller AC breaker size. This setting is very dependent on the stability of the AC source. If using a generator, factors such as altitude and output voltage regulation may require a lower setting than the generator's breaker size. If the input breaker to the charger is tripping, because it is a weak breaker, try reducing this setting to next lower level.



CAUTION: The Shore Max setting does not limit the current to the inverter loads. If the current from the loads on the output of the inverter are greater than the circuit breaker rating on the incoming AC source, you may experience nuisance tripping of this breaker.

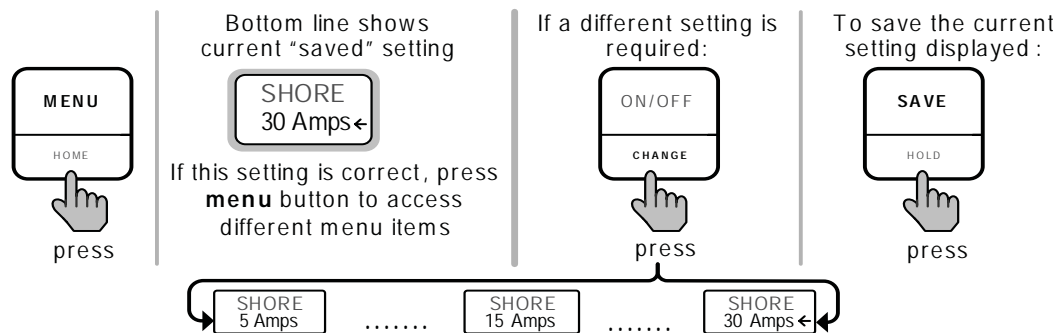

Figure 3-1, SHORE: Shore Max Selections

Setup

- **SETUP: 02 SEARCH** - Allows you to turn off the Search Watts feature or adjust the power level to determine when the search watts feature becomes active. The power level range selection is 0W(off) to 20W. If this feature is not needed, select Search=Off. When search is turned off, the inverter continuously provides full AC voltage to the loads.

Default setting: Search= 5W.



Info: When the Search Watts feature is active, "Search" appears on the top line of the LCD display and the green 'INV' LED will slowly flash.

What is the Search watts feature? This feature is used to help save battery power by reducing the inverter's output to search pulses when there is no detectable load. If someone turns on a load greater than the wattage level setting while the inverter is searching, the inverter will start inverting to provide full voltage on its output.

Should I use the Search watts feature? If the inverter can spend a great deal of time searching (to reduce the power drain on your batteries) and you can tolerate small loads (less than 5 watts) from being on, then the search mode feature should be used. However, if you require some small load (i.e. digital clocks, satellite receivers, answering machines, etc.) to always be on, then this feature should be turned off (Search = Off).

I want to use the Search watts feature, how do I determine where to set it? The search watts setting should be adjusted to the same power level (or the next lower setting) of the smallest load that you want to run. If you don't know the wattage of the smallest load you want to run, turn the load on and decrease the Search watts setting until the load comes on and stays on.

Example: You have reviewed all the loads you want to run and determined that the smallest load is a 20 watt light, then set the Search = 20W. Whenever you turn on any load (because all the loads are greater than 20 watts), the inverter will stop searching and start inverting to deliver power to the load.



Info: Even though the search feature is on, some connected equipment may draw enough current even while off keep the inverter in the "invert".

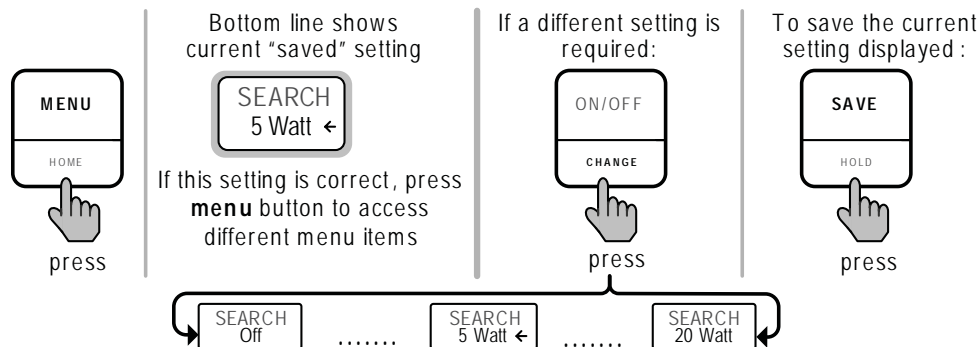

Figure 3-2, SEARCH: Search watts

- **SETUP: 03 Batt AmpHrs** - Used to select the most approximate capacity of the battery bank connected to the inverter. This setting determines the time the battery charger is in the Absorb Charging stage (i.e. Absorption Time). See Table 3-1 to correlate the battery capacity to the Absorption Time.

Default setting: Batt AmpHrs= 400

Table 3.1, Battery AmpHrs to Absorb Charging Time

Battery AmpHrs Selected	Absorb Charging Time
Batt AmpHrs = 200	60 minutes
Batt AmpHrs = 400	90 minutes
Batt AmpHrs = 800	120 minutes

Where do I set the Battery Amp-Hour setting? Select the setting based on the 20-hour Amp-Hour (AH) capacity of your battery bank.

How do I determine my Battery Amp-Hour capacity? The inverter requires deep cycle batteries, which are specifically made for continuous use. Deep cycle batteries are rated either by a) amp-hours or b) reserve capacity in minutes.

- Amp-hour (AH) capacity is a measurement of how many amps a battery can deliver for a specified length of time (usually 20 hours) until the voltage achieves 1.75 VDC / cell at 80° F.
- Reserve Capacity (RC) is a measure of how many minutes a battery can deliver a certain amount of current (usually 25A) and maintain a voltage above 1.75 VDC/cell at 80° F.



Info: If using the Reserve Capacity (25A), the 20-hour AH capacity can be estimated by multiplying "minutes reserve capacity" by 25%.

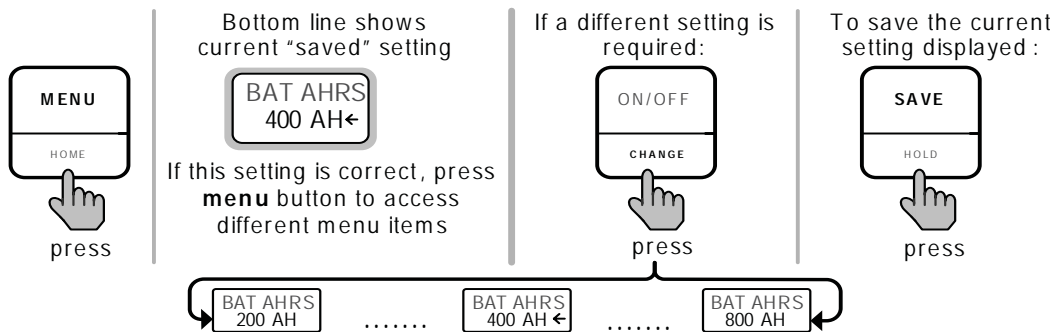

Figure 3-3, SETUP: 03 Batt AmpHrs Selections

Setup

Table 3.2 below provides an estimated 20-hour Amp-Hour capacity based on the group/code size, physical size and voltage of the battery. If you are not sure of your battery's 20-hour AH rating, consult your battery manufacturer/dealer or use the table below to obtain an estimate.

Table 3.2, Battery Size to Battery Amp-Hours (estimated)

Group / Code Size	Physical Size (L" x W" X H")	Battery Voltage	Battery AHrs (20-hour rate)
GC-2 (Golf Cart)	10 3/8 x 7 13/16 x 10 5/8	6V	220 AmpHrs
L16	11 11/16 x 7 x 16 11/16	6V	375 AmpHrs
Group 22	9 1/2 x 6 7/8 x 8 5/16	12V	55 AmpHrs
Group 24	10 1/4 x 6 13/16 x 8 7/8	12V	70 AmpHrs
Group 27	12 1/16 x 6 13/16 x 8 7/8	12V	95 AmpHrs
Group 31	13 x 6 13/18 x 9 7/16	12V	110 AmpHrs
4D	20 3/4 x 8 3/4 x 9 7/8	12V	200 AmpHrs
8D	20 3/4 x 11 1/8 x 9 7/8	12V	225 AmpHrs

Once you've determined the Amp-hour capacity of each battery, review how your batteries are connected (parallel or series) to determine the total amp-hour capacity of the battery bank:

Parallel connection – batteries connected in parallel (positive to positive, negative to negative) increase the amp-hour capacity of the battery bank, but the voltage remains the same.

For example: You have a 12-volt battery bank with three 12-volt batteries that are rated at 125 Amp-Hours (AH) each. Each of the positive terminals are connected together and each of the negative terminals are connected together, which means they are connected in parallel. The amp-hours of each battery connected in parallel are added together (125 AH + 125 AH + 125 AH = 375 AH), but the voltage of the battery bank stays the same (12 VDC).

Series connection - batteries connected in series (positive to negative) increase the voltage of the battery bank, but the amp-hour rate remains the same.

For example: You have a 12-volt battery bank with two 6-volt batteries that are rated at 220 amp-hours. The positive terminal of the first battery is connected to the negative terminal of the second battery, which means these batteries are connected in series. Since the two 6-volt batteries are connected in series, the voltage of the batteries are added together to produce 12-volts (6 VDC + 6 VDC = 12 VDC), but the amp-hour capacity of the battery bank does not change (220 AH).

In battery banks where you have batteries connected in series and in parallel –the rules are the same. The batteries connected in series are referred to as a "series string" and the amp-hour capacity doesn't change. Each "series string" is connected together in parallel to increase the amp-hour capacity. Add the amp-hour capacity of each "series string" connected in parallel to determine the total amp-hour capacity of the battery bank.

- **SETUP: 04 Battery Type** - Used to select the battery type, which determines the battery charge profile and ensures the batteries are receiving the proper charge voltage. The fixed voltage selections are GEL (for Gel batteries), Flooded (for liquid lead acid batteries), AGM 1 (for Lifeline AGM batteries) and AGM 2 (for East Penn/Deka/Discover/Trojan AGM batteries); See Table 3.3 to determine the specific charge voltage based on the Battery Type selected.

Default setting: BattType = Flooded



Info: The voltage settings shown in Table 3.3 are based on the Battery Temperature Sensor (BTS) being disconnected or at a temperature of 77° F (25° C). If the BTS is connected, the actual charge voltage will increase if the temperature around the BTS is colder than 77° F (25° C) and decrease if hotter than 77° F (25° C). This ensures the batteries receive the correct charge voltage even if they become cold or hot.

Table 3.3, Battery Type to Charge Voltages

Battery Type	Inverter Voltage	Absorption Voltage	Float Voltage	Equalization Voltage
GEL	12 VDC	14.1 VDC	13.6 VDC	14.1 VDC ¹
	24 VDC	28.2 VDC	27.2 VDC	28.2 VDC ¹
	48 VDC	56.4 VDC	54.4 VDC	56.4 VDC ¹
Flooded	12 VDC	14.6 VDC	13.4 VDC	15.5 VDC
	24 VDC	29.2 VDC	26.8 VDC	31.0 VDC
	48 VDC	58.4 VDC	53.6 VDC	62.0 VDC
AGM 1 ²	12 VDC	14.3 VDC	13.1 VDC	15.5 VDC
	24 VDC	28.6 VDC	26.2 VDC	31.0 VDC
	48 VDC	57.2 VDC	52.4 VDC	62.0 VDC
AGM 2 ³	12 VDC	14.5 VDC	13.5 VDC	14.5 VDC ¹
	24 VDC	29.0 VDC	27.0 VDC	29.0 VDC ¹
	48 VDC	58.0 VDC	54.0 VDC	58.0 VDC ¹

Note 1: voltage same as absorption voltage - to prevent equalization.

Note 2: specifications for Concord (Lifeline Series) AGM batteries.

Note 3: specifications for East Penn, Deka, Discover and Trojan AGM batteries.

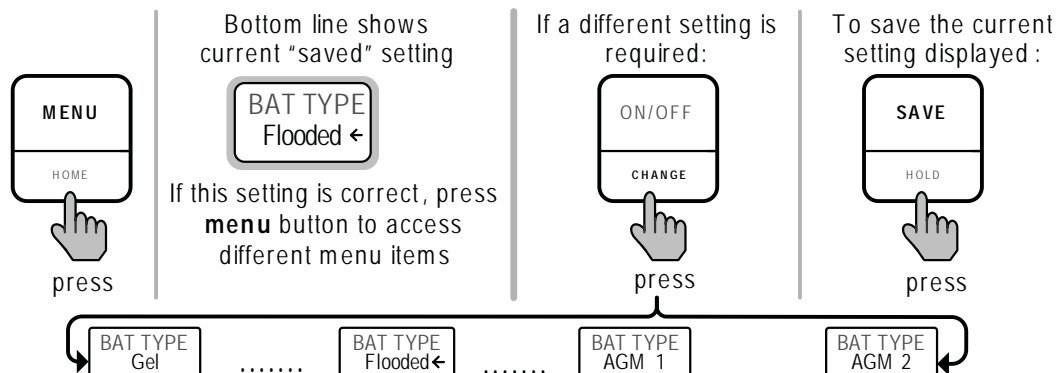

Figure 3-4, SETUP: 04 Battery Type Selections

Setup

- **SETUP: 05 Charge Rate** - Used to set the maximum charge rate allowed to charge the batteries during bulk, absorption, float and equalize charging. Selections are 'Max Charge = 10%' up to 'Max Charge = 100%'. The *Max Charge = 10%* setting is available to help minimize charging while continuing to allow pass-thru power.

The *Max Charge* selections are provided as a percentage of the inverter/charger's maximum charging capability. Refer to label on the side of the inverter or the operator's manual for the inverter/charger to determine its maximum charge rate. Once you find this maximum charge rate, determine the percentage needed to limit the charge rate to your battery bank.

For example, if the maximum charge rate of your inverter/charger is 100 amps and you need to limit the charge rate to 50 amps, choose the *Max Charge = 50%* selection (50 amps = 50% of 100 amps).

Default setting: Max Charge = 100%



Info: The topology of the Magnum inverter, when connected to an AC source, will override the setting and start charging if the battery voltage is <7 VDC (12 VDC models), <14 VDC (24-volt models) or <28 VDC (48-volt models).

How do I determine where to set my maximum charge rate? The maximum charge rate is generally set to a C/5* rate (C = the total amp-hour capacity of the battery bank - using the 20-hour AH rate). The C/5 rate is usually used when the objective is to charge the batteries as quickly as possible (i.e. 400 AH ÷ 5 = 80 amp maximum charge rate). A lower rate such as C/20* is used when the batteries need to be charged as slow as possible. The ME-MR provides 3 settings for charge rate adjustment and they are 10, 50 and 100%; multiply this percentage and the max charge rate of the inverter to find the closest setting to the desired charger output.



CAUTION: The C/5 or C/20 charge rate settings are guidelines; they are not requirements on how you should set your battery charge rate. For specific charge rate requirements, refer to your battery manufacturer.



Info: If multiple inverter/charger's are used on a single battery bank, you must ensure that the total charge rate from all inverter/chargers is limited to the maximum charge rate needed for your battery bank. This Charge Rate setting only limits the charging on each inverter/charger individually, not on all inverter/chargers.

* C/5 or C/20 rate - Charge rates are commonly expressed as a ratio of the total amp-hour (AH) capacity of the battery bank. For example, with a 400 AH battery bank (C = 400), the C/5 charge rate is 80 A (400/5 = 80 A).

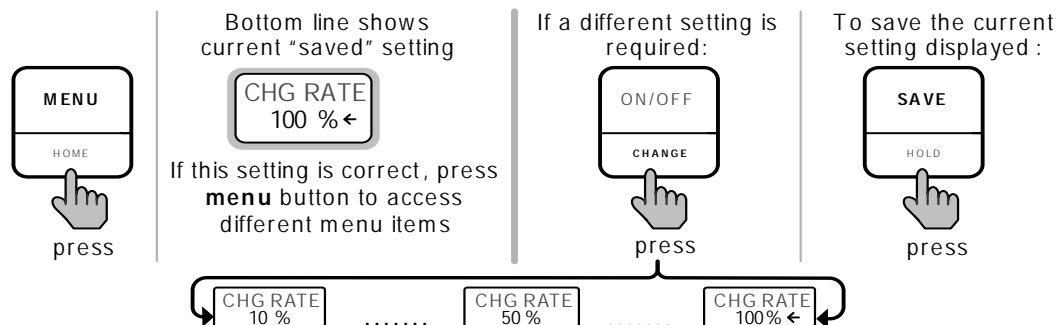

Figure 3-5, SETUP: 05 Charge Rate Selections

• **SETUP: 06 LowBattCutOut** - The Low Battery CutOut (LBCO) setting is used to set the DC voltage level that turns off the inverter to help protect the batteries from over-discharge damage. Selections are from 9 VDC to 11 VDC (12-volt inverter models), 18 VDC to 22 VDC (24-volt inverter models), or 36 to 44 (48-volt inverter models). If the battery voltage drops below the LBCO selected setpoint continuously for more than 1 minute, the fault LED will come on, the inverter will turn off, and the display will show a 'Low Bat' (low battery) status. If the battery voltage falls below 8.5 volts (12-volt models), 17.0 volts (24-volt models), or 34.0 (48-volt models); the fault LED and 'Low Bat' status will be immediate.

Default settings: LBCO = 10 VDC (12-volt models), 20 VDC (24-volt models) or 40 VDC (48-volt models).



Info: The inverter will automatically begin to start inverting when the DC voltage increases to ≥ 12.5 VDC (12-volt models), ≥ 25.0 VDC (24-volt models) or ≥ 50.0 VDC (48-volt models). If AC power is available and connected to the inverter's input, the inverter will automatically clear the 'Low Battery' fault, pass the input AC power to the output and begin charging the batteries.

Where do I set the LBCO setting? If you want to cycle the batteries slightly - but don't want to discharge them more than 20%*, then the LBCO setting should be set from 11 VDC (12-volt models), 22 VDC (24-volt models) or 44 VDC (48-volt models). In some applications, such as installed in an off-grid home or doing a lot of dry-camping in your RV, you may want to cycle down to 25%* by setting the LBCO from 10 VDC (12-volt models), 20 VDC (24-volt models) or 40 VDC (48-volt models). In extreme circumstances, you have the ability to discharge the batteries to 80%* by setting the LBCO to 9 VDC (12-volt models), 18 VDC (24-volt models), or 36 (48-volt models) before recharging.

* These discharge percentage are rough estimates; for accurate battery monitoring, a battery monitor such as Magnum's ME-BMK and the ME-RC is required.



Info: The higher the LBCO setting, the shallower the discharge of the batteries; which should allow the batteries to have a longer life. The downside to a higher LBCO setting is that you need to charge more often to prevent the inverter from shutting down.

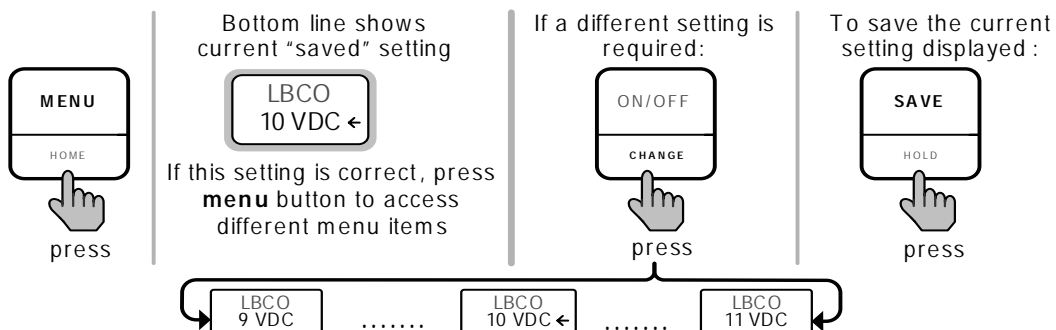

Figure 3-3, LBCO: Low Battery Cut Out

Setup

SETUP: 07 VAC Dropout - Used to select the minimum AC voltage that must be present on the input before the inverter/charger switches from inverter to charger mode. For example: If this setting is set to Dropout = 60 VAC, then the AC input voltage must be above 60 Volts before the inverter will switch from inverter mode to charge mode. This setting also determines the minimum AC voltage threshold where the inverter/charger transfers from the AC input (utility/shore or generator) and begin inverting. This protects AC loads from utility outages. For example: If this setting is set to Dropout = 60 VAC, when the AC input voltage drops to 60 volts, the inverter will switch from charge mode to inverter mode. Selections are Dropout = 60 VAC to Dropout = 100 VAC for 120v units (i.e. North American units), and 110 VAC to 190 VAC for 230v (i.e. export).

Default setting: Dropout = 80 VAC for North American units, 150 VAC for Export products.

Where do I set my VAC Dropout? It depends on the application and what you are using as the AC source. The settings not only look at the incoming voltage to determine when to transfer, but also determines the response sensitivity to incoming voltage fluctuations. Use a VAC Dropout setting above 80 VAC (>80 VAC) when the AC source is well regulated and operating devices that are sensitive to voltage fluctuations. These settings are intolerant of voltage fluctuations and provide a quicker transfer. The transfer time from charge mode to inverter mode is about 16 milliseconds when using these settings (Dropout = 80 VAC to Dropout = 100 VAC). Use the 80 VAC or lower setting (≤ 80 VAC) when the AC source may have significant fluctuations in RMS voltage. These settings are highly recommended if using a generator for charging. The transfer time from charge mode to inverter mode is >16 milliseconds when using these settings (Dropout = 60 VAC to Dropout = 80 VAC).

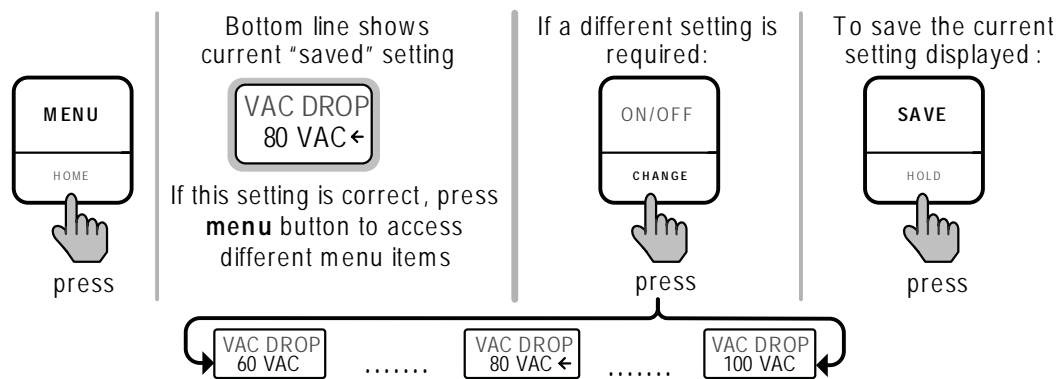
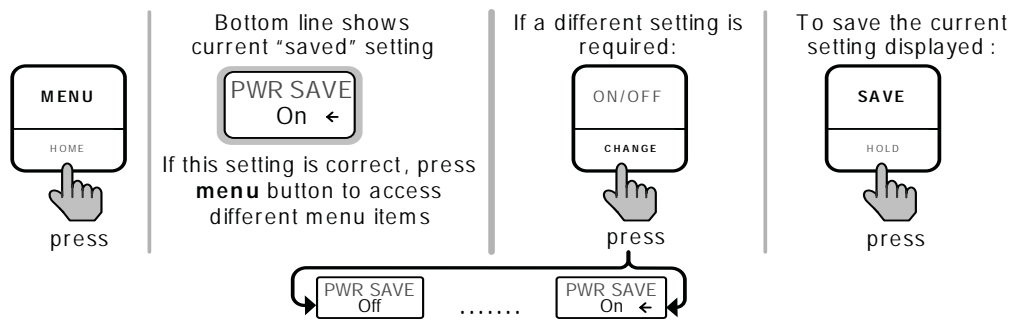

Figure 3-7, SETUP: 06 VAC Dropout Selections

- **SETUP: 08 Power Saver™** - This setting allows you to turn on/off the Power Saver™ feature.

Default setting: Pwr Save = On

What is the Power Saver™ feature? The Power Saver™ feature causes the LCD backlight and LED's on the remote display to turn off to conserve energy. The remote goes into Power Saver™ mode if there hasn't been a pushbutton press or fault message for 15 minutes. Whenever the remote goes into the Power Saver™ mode, the LCD backlight and LED's can be reactivated by pressing any menu pushbutton. If you have a fault during the Power Saver mode, the LCD backlight and Fault LED will come on and stay on as long as the fault is detected. If you want the LCD backlight and LED's to always be on, you will need to turn the Power Saver feature off by selecting *PwrSave = Off*.



- **SETUP: 09 Equalize** - This setting allows you Equalize the batteries after a Float Charge is achieved. Equalize is a controlled overcharge of the batteries and should only be attempted by experienced users.

Default setting: Equalize = Disabled

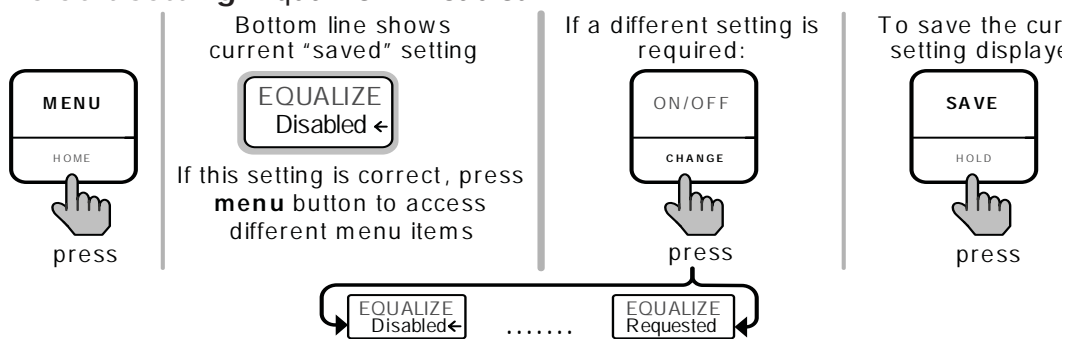

What is the Equalize? Equalize is a controlled overcharge of the batteries. There will be excessive gassing of the batteries during the Equalize process. This condition is corrosive and emits dangerous hydrogen gasses during the charging process.



Warning: Only Equalize in well ventilated areas. Consult your battery manufacturer for recommendations on Equalizing batteries.



Info: Equalization charging is not available if GEL or AGM 2 is selected under the *SETUP: 04 Battery Type* menu.

Setup

3.3 TECH Menu

The TECH menu pushbutton provides access to selections that are used to assist service technicians in troubleshooting. It provides access to system information along with a selection that allows all system settings to be returned to the original factory default values.

Scroll to the end of the SETUP menus until "TECH, Press ON" appears. Push the ON-OFF / Change button to access the tech menus. Continue to press the ON-OFF/Change button to see more tech menus.

TECH: 01 Temperatures – This "read only" menu displays temperature readings of the battery temperature sensor (if connected), the transformer, the FET's (Field Effect Transistors).

TECH: 02 Revisions – This "read only" menu displays the firmware revision level of the inverter and remote.

TECH: 03 Inv Model – This "read only" menu displays the model number of the connected inverter.

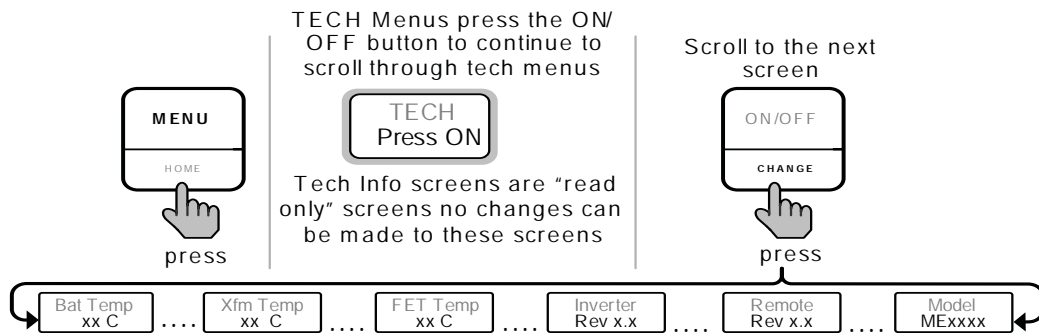

Figure 3-10, Tech Menu.



Info: When "Model: UNKNOWN" is displayed, the remote is not able to determine the inverter model, this is due to an older inverter model or an inverter revision newer than the remote; all remote menu selections and features that are available in the inverter will function normally.

Table 3.4, Inverter/Charger Default Settings

	Default Setting
01 Shore	Shore Max = 30A
02 Search Watts	Search = 5W
03 Batt AmpHrs	Batt Amphrs = 400 AmpHrs (Absorb Time = 90 minutes)
04 Battery Type	BatType = Flooded
05 Charge Rate	Max Charge = 100%
06 Low Battery Cut Out	LBCO = 10 VDC (12-volt models), 20.0 VDC (24-volt models); or 40.0 VDC (48-volt models).
07 VAC dropout	Dropout = 80VAC (150VAC for export)
08 Power Save™	PwrSave = On (15min)
09 Equalize	Disabled

Setup

4.0 Menu Map: ME-MR Remote Control

The following figure is a complete overview of the inverter/charger settings and info displays available in the ME-MR; this should help with menu navigation.

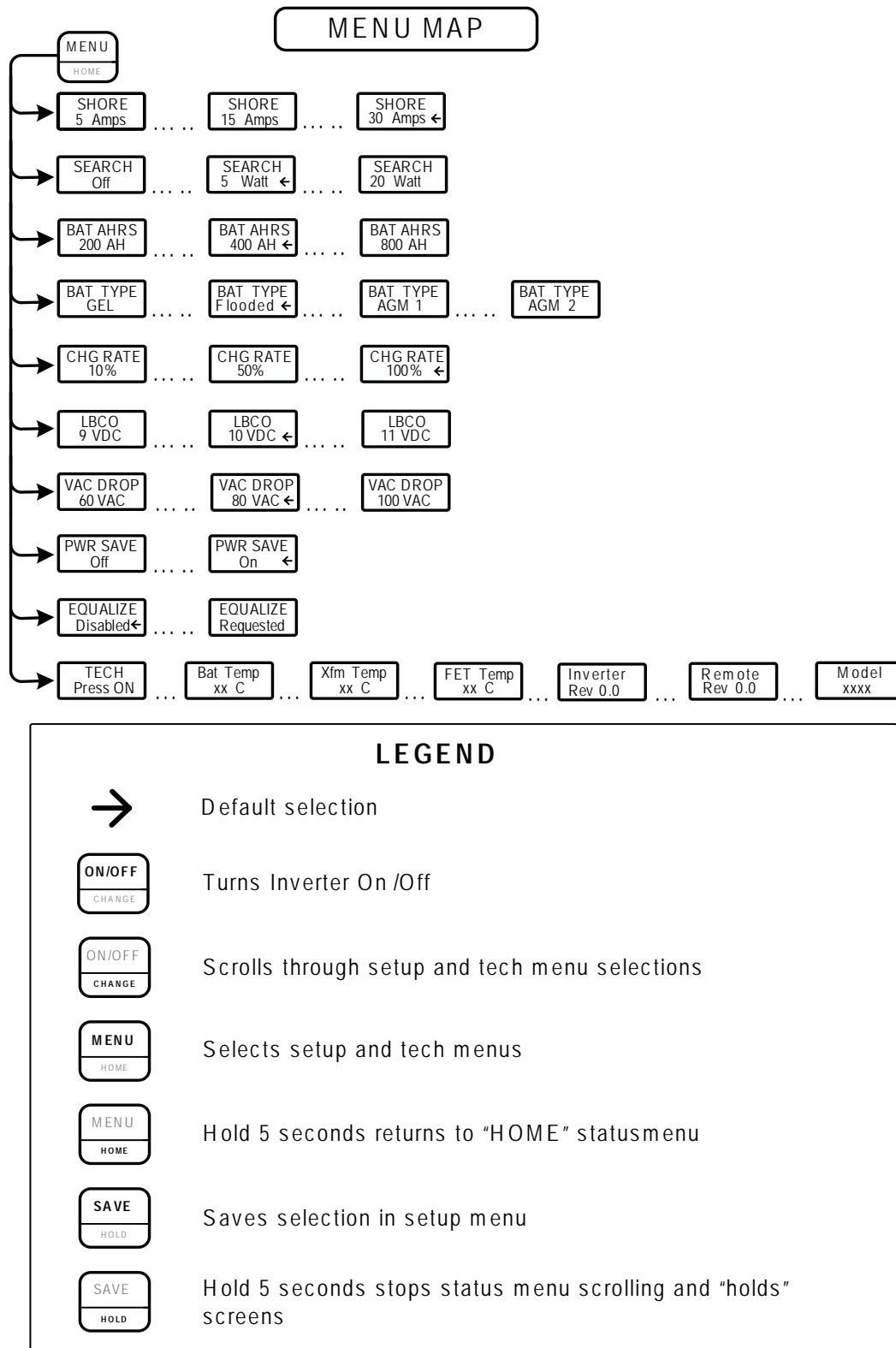

Figure 4-1, Inverter/Charger Menu Map

5.0 Operation

This section explains how to operate the inverter/charger. It also helps to explain the operational status determined by the LED indicators and LCD display.

5.1 Front Panel

The ME-MR front panel contains LEDs and a LCD display for viewing system status; pushbuttons to control system operation.

Figure 5-1, ME-MR Front Panel Controls and Indicators

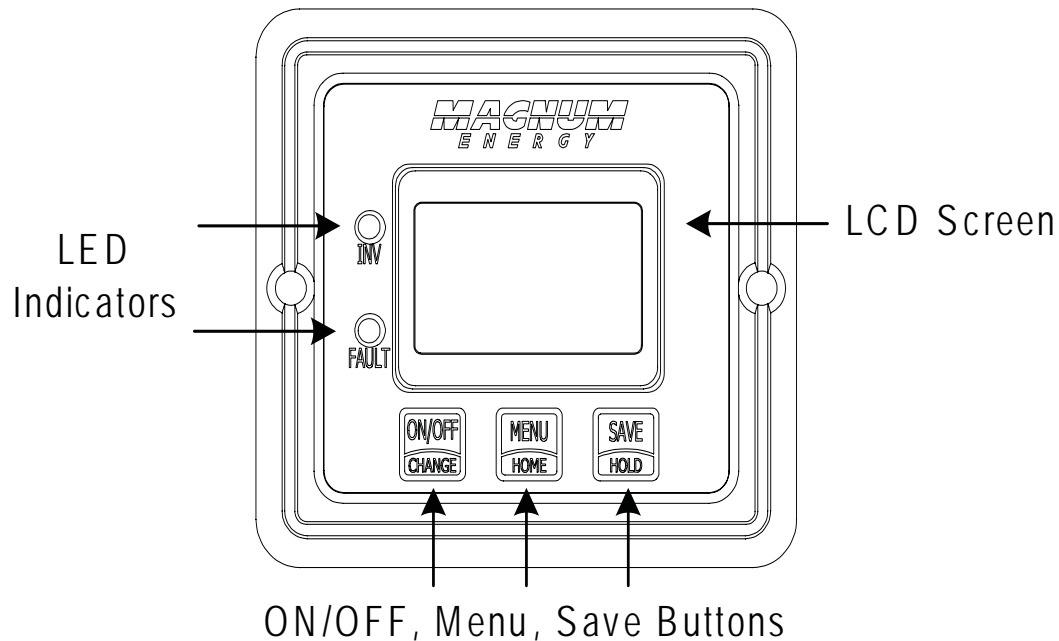

5.1.1 LED Indicators

There are two LED's indicators on the front panel that light solid or blink to indicate the inverter/charger's status. When the remote is first powered up, both LED's come on as it goes through a self-test. Once the self-test is complete, the LED's along with the LCD provide the operating status of the inverter/charger. See section 5.3.4 for the LED Indicator Guide.

5.1.2 LCD Display

The LCD display is used for setting up the system operation as well as viewing the current operating status or any fault condition. This display has two lines of alphanumeric characters and features a back-light that can be set to turn off to conserve power. The top and bottom lines provides the inverter/charger status, setup menus and tech information which is detailed in this section. This display automatically powers up with the current system status on the top line and the Home Screen on the bottom line.

Operation

5.1.3 ON/OFF Pushbuttons

ON/OFF: This pushbutton toggles the inverter function on and off. The green "INV" LED turns on and off with the pushbutton.

5.1.4 MENU Pushbutton

MENU: This pushbutton provides quick access to menu items that can help with configuring, monitoring and troubleshooting your inverter/charger.

5.1.5 SAVE Pushbutton

SAVE: This pushbutton saves the changes to settings selected in the Setup Menus.

5.1.6 CHANGE Pushbutton

CHANGE: This pushbutton scrolls through the selections available under each menu heading for SETUP and TECH menus. This menu will restart if you missed the desired selections, so if a selection is bypassed simply continue to press the MENU pushbutton until the desired selection appears.

5.1.7 Home Pushbutton

Home: Holding down on the Home button for 5 seconds exits SETUP menus and returns to the status screen.

5.1.8 Hold Button:

Hold: Holding down on the Hold button for 5 seconds stops the status screen from scrolling. Holding down again on the Hold button returns the status screen to scrolling.



Info: All adjustable inverter/charger settings in the ME-MR are saved in non-volatile memory and are preserved until changed - even if an inverter reset is performed or if all power to the remote or inverter is removed.



Info: The ME-MR remote control is an inverter only controller. In order to display a Magnum Energy accessory you need to use the ME-RC50 remote control. Please refer to the ME-RC50 remote control manual on the Magnum Energy website at www.magnumenergy.com for further information on displaying accessories.

5.2 Operating the Inverter/Charger

Turning the inverter on: Press the ON/OFF pushbutton to activate the inverter function. The inverter will either be actively inverting by using power from the batteries to power the AC loads (see figure 5-4); or will be searching for a load by using very little power from the batteries - if in search mode (see figure 5-3). The green 'INV' LED will be on when the inverter is actively inverting and the green 'INV' LED will flash while searching.

Turning the inverter off: While the inverter is actively inverting or searching, the ON/OFF INVERTER pushbutton can be pressed to switch the inverter function off and this will turn the green 'INV' LED off (see figure 5-2).

Inverter Standby: The inverter is in standby when the inverter is active (green 'INV' LED is on) and an external AC power (utility/shore or generator) is passing through the inverter to power the AC loads. During normal operation, the AC loads will be powered by the external AC power, however, if a blackout or brownout condition occurs, the inverter senses these conditions, transfers to inverter mode and powers the AC loads connected to the inverter.



CAUTION: If you have critical loads and in Inverter Standby, do not press the ON/OFF pushbutton to turn the inverter function off. If the green 'INV' LED is off, inverter power will NOT be available to run your critical loads if the external AC power is interrupted.

Equalize charging: Equalizing is a controlled-overcharge performed after the batteries have been fully charged. It helps to mix the battery electrolyte (to reverse stratification) and also helps to remove sulfation that may have built up on the plates. These conditions, if left unchecked will reduce the overall capacity of the battery.



WARNING: Do not perform an equalization charge without reading and following all safety precautions pertaining to charging/equalization as noted in this manual and any equalization information in the inverter's manual.

To enable the equalization charge; see figure 5-10 and follow all related information on page 25.

5.3 System Status Messages

The remote control uses the top line of the LCD display to show the inverter/chargers operation by displaying a status message. This section will show the inverter/charger's operating modes and the available status messages under each mode. Use these status messages along with the Status LED's to determine the inverter/charger's current operating status and to help troubleshoot the system if a fault occurs.

There are three operating modes of the inverter/charger:

- Inverter Mode
- Charger Mode
- Fault Mode

Operation

5.3.1 Inverter Mode Messages

The inverter/charger will be in the Inverter Mode when AC power (shorepower/utility or generator) is not available or unacceptable to the inverter/charger's input. The Inverter Mode messages are Off, Searching and Inverting.

Off appears on the LCD; all LED's are off.

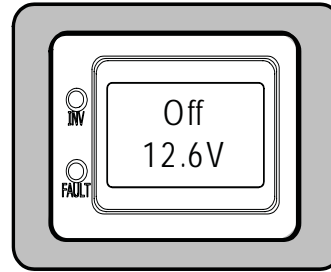

Figure 5-2, Off Mode

- **Off** – This message tells you that there is no AC available on the inverter's AC output. The inverter function is off and there is no utility/shore or generator power AC sensed on its input.

Search appears on the LCD. The INV (green) LED slowly flashes. The FAULT (red) is off

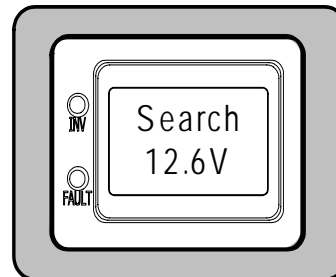

Figure 5-3, Search Mode

- **Search** – The inverter is in the Search mode, which means the AC loads on the inverter output are less than the *SETUP: 01 Search* watts setting. The search mode function is used to reduce the inverter draw from the battery and may be turned off at any time if you want full inverter output voltage available at all times (see the *SETUP: 02* section).

Invert appears on the LCD. The INV (green) LED's are on solid. The FAULT (red) LED is off.

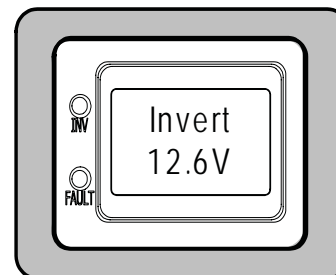

Figure 5-4, Inverting Mode

- **Invert** - The inverter is providing AC voltage on its output by inverting power from the batteries.

5.3.2 Charger Mode Messages

When AC power (utility or generator) is connected to the inverter/charger, it begins to monitor the AC input for acceptable voltage. Once the AC input is accepted, the AC transfer relay (inside the inverter) closes and charger mode begins. There are several charger mode messages; view the top line of the LCD display and the corresponding message in this section to determine and understand the particular charger mode.



Info: The AC input becomes acceptable after a minimum 10 second delay and when the voltage is greater than the *SETUP: 06 VAC Dropout* setting.

Charge appears on LCD; FAULT (red) LED is off and INV (green) LED could be on or off.

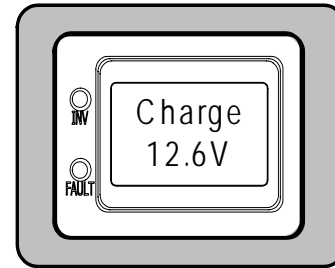

Figure 5-5, Charging Mode

- **Charge** – Once the charger mode has been enabled, the unit will wait and display “Charge” to determine the charge routine. If the DC voltage is low (≤ 12.8 VDC / 12-volt models, ≤ 25.6 VDC / 24-volt models, or ≤ 51.2 VDC / 48-volt models), the charger will initiate “Bulk Charging”. If the DC voltage is higher than this voltage, the charger will skip the Bulk and Absorb charging stages and go directly to Float Charging.

Bulk appears on LCD; FAULT (red) LED is off; INV (green) LED could be on or off.

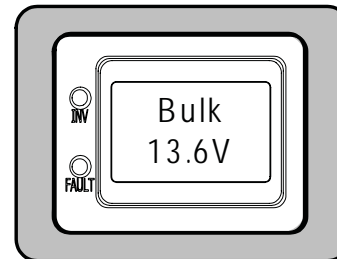

Figure 5-6, Bulk Charging Mode

- **Bulk Charging** – The battery charger is delivering maximum current (determined by the *SETUP: 05 Charge Rate* setting) to the batteries. The charger will remain in bulk charge until the absorb voltage (determined by the *SETUP: 04 Battery Type* setting) is reached.

Absorb appears on LCD; FAULT (red) LED is off and INV (green) LED could be on or off.

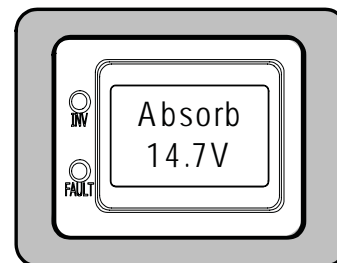

Figure 5-7, Absorb Charging Mode

- **Absorb Charging** - The absorb stage is the constant voltage stage and begins when the absorb voltage is reached (determined by the *SETUP: 04 Battery Type* setting) while bulk charging. During this stage, the DC charging current decreases as the battery becomes charged. This charge stage continues until the Absorb Charging time (determined by the *SETUP: 03 Battery AmpHrs* setting) is finished.

Operation

Float appears on LCD; FAULT (red) LED is off and INV (green) LED could be on or off.

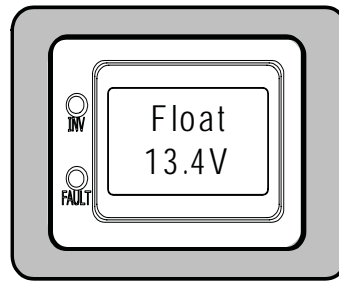

Figure 5-8, Float Charging Mode

- **Float Charging** – At the end of the Absorb Charging time, the charger reduces the charge voltage and tries to maintain the batteries at the float charge voltage setting; which is determined by the *SETUP: 04 Battery Type* setting as shown in Table 3.3, Battery Type to Battery Charge Voltages.



Info: If the battery voltage falls ≤ 12.1 VDC (12-volt models), ≤ 24.2 VDC (24-volt models) or ≤ 48.4 VDC (48-volt models); the unit will begin bulk charging.

Full Chg appears on LCD; FAULT (red) LED is off and INV (green) LED could be on or off.

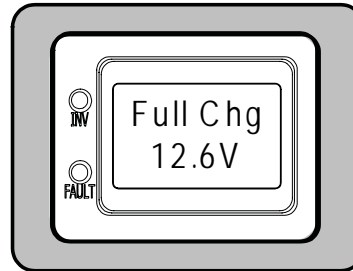

Figure 5-9, Full Charge Mode

- **Full Charge** – This status indicates that you have entered the Battery Saver™ mode. This mode maintains the batteries without overcharging, thus preventing excessive loss of water in flooded batteries or drying out of GEL/AGM batteries. After 4 hours "Float Charging", the charger will turn off and "Full Charge" is displayed (charger is now in Battery Saver™ mode). If the battery voltage drops to ≤ 12.6 (12-volt models), ≤ 25.2 (24-volt models) or ≤ 50.4 (48-volt models); the charger will automatically initiate another 4 hours "Float Charging". This cycle helps to ensure the batteries are monitored and maintained; and continues as long as AC power is continuously connected to the AC input.

Equalize appears on LCD; FAULT (red) LED is off and INV (green) LED could be on or off.

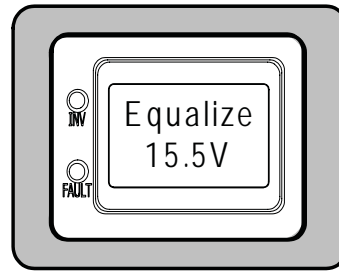

Figure 5-10, Equalizing Mode

Equalizing - The battery charger is delivering the equalize voltage to the batteries; see Table 3.3, *Battery Type to Battery Charge Voltages* to determine the equalize voltage for your battery type.

Equalize charging can be enabled by selecting the function in SETUP: 09 Equalize. Equalization charging can only be enabled while the charger is in float charge or in Battery Saver mode. To turn on equalize charging, ensure the LCD display reads "Float" or "Full Chg", then press MENU button until "EQUALIZE Disabled" appears in the display, then press the CHANGE button. The display should read "EQUALIZE Requested", then "EQUALIZE Started"

The equalize charge will continue for 4 hours and then automatically stop and return to "Float Charging". The equalize charge can be manually stopped by pressing the MENU button until "EQUALIZE Started" appears in the display, then press the CHANGE button. The display should read "EQUALIZE Disabled".

During equalize charge stage the batteries will begin gassing and bubbling vigorously which consumes water; ensure each cell has adequate distilled water levels prior to equalizing and add water as needed after equalizing.

How often should I equalize? Some experts recommend that heavily used batteries should be equalized periodically, ranging anywhere from once a month to once or twice per year. Other experts only recommend equalizing when the cells have a low specific gravity or when the difference between any individual cell has a specific gravity reading greater than .015 after being fully charged.

How long should I equalize? While the batteries are gassing, monitor the specific gravity readings every hour; when the specific gravity readings no longer increase, the equalization charge is complete and should be stopped.



WARNING: Equalizing produces hydrogen and oxygen gas. Ensure the battery compartment has adequate ventilation in order to dissipate this gas to avoid explosions.



CAUTION: Ensure you batteries can be equalized - only equalize your batteries if permitted by your battery manufacturer or dealer. Performing an equalize charge on batteries other than liquid lead acid or certain AGM types could permanently damage them. Refer to your battery manufacturer/dealer for instructions on how to properly equalize your batteries.



CAUTION: Ensure the DC loads will not be damaged by the higher voltage applied to the batteries during the equalize charge. If in doubt, disconnect the DC loads to prevent damage.



Info: Equalization charging is not available if GEL or AGM 2 is selected under the *SETUP: 04 Battery Type* menu.

Operation

5.3.3 Fault Mode Messages

The fault LED comes on and a fault status is displayed when an abnormal condition is detected. View the LCD display and the information in this section to determine and correct the issue.



Info: Many of the faults will automatically restart when the fault is cleared. Some faults will require a manual restart; this requires the ON/OFF button on the remote to be pressed and released. Finally, if the fault is unable to clear, an inverter reset may be required - see section 6.2 to perform an inverter reset.

5.3.3.1 System Fault messages - These fault messages are usually caused by some external issue that directly affects the inverter/charger system.

Low Bat appears on the LCD and the FAULT (red) LED is on. The INV (green) LED's is off.

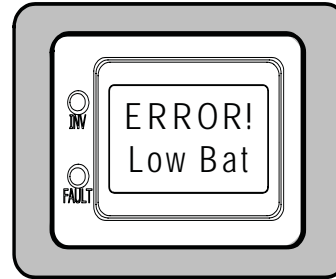

Figure 5-11, Low Battery Fault

- **Low Battery** – The inverter turned off to help prevent the batteries from being over-discharged. This message is displayed and the FAULT (red) LED illuminates when the battery voltage drops below the *SETUP: 06 LBCO* setting for more than 1 minute. The inverter will automatically restart and resume operation when the battery voltage rises to ≥ 12.5 VDC (12-volt models), ≥ 25.0 VDC (24-volt models), or ≥ 50.0 VDC (48-volt models).



Remedy: This fault will also automatically restart if AC power (such as utility/shore power or a generator) is connected to the inverter/charger's input and battery charging begins.

High Bat appears on the LCD and the FAULT (red) LED is on. The INV (green) LED's is off.

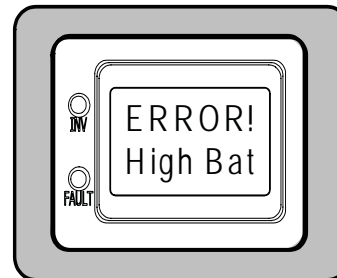

Figure 5-12, High Battery Fault

- **High Battery** – The inverter has turned off because the battery voltage is at a very high level. This fault message is displayed and the FAULT (red) LED will be on when the battery voltage is above the High Battery Cut-Out (HBCO) value. This inverter will automatically restart and resume operation when the battery voltage drops.



Info: The HBCO value is dependent on your inverter revision and model. Normally, the HBCO value for the ME/MM/RD Series inverters is 16 VDC (12-volt models) or 32 VDC (24-volt models); and the HBCO value for the MS/MMS Series inverters is 17 VDC (12-volt models), 34 VDC (24-volt models), or 68 VDC (48-volt models).



Remedy: This fault usually only occurs when an external DC charging source is charging the inverter's battery bank. Turn off any other additional charging source to allow the DC voltage level to drop.

Overtemp appears on the LCD and the FAULT (red) LED is on. The INV (green) LED's is off.

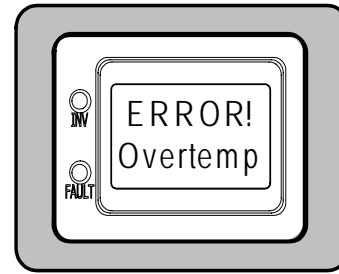

Figure 5-13, Overtemp Fault

- **Overtemp** – This fault message indicates the inverter/charger has shut down because the internal power components (FET's and/or Transformer) have exceeded their safe temperature operating range. When the unit has cooled down, it will automatically restart and continue operation.



Remedy: If the fault occurs while inverting, reduce the load on the inverter; if it occurs while charging, turn down the charge rate. If this fault happens often, ensure the inverter is not in a hot area, has proper ventilation and the cooling fans inside the inverter are working.

AC Ovrld appears on the LCD and the FAULT (red) LED is on. The INV (green) LED's is off.

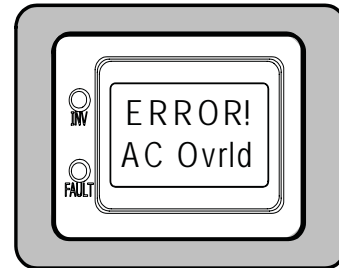

Figure 5-14, AC Overload Fault

- **AC Overload** - This fault message displays when the AC load on the inverter/charger's output has exceeded the inverters AC current protection limits. If the overload condition lasts for less than 10 seconds, the unit will automatically restart and resume operation. However, if the overload occurs more than 10 seconds, the unit will shut down and will require a manual restart.



Remedy: This fault usually occurs because the connected AC loads are larger than inverter's output capacity, there is a wiring short on the output or the output wires are incorrectly wired. Once the AC loads are reduced or the output wiring is corrected; the inverter can be restarted after a manual restart has been accomplished.

Operation

High ACV appears on the LCD and the FAULT (red) LED is on. The INV (green) LED's is off.

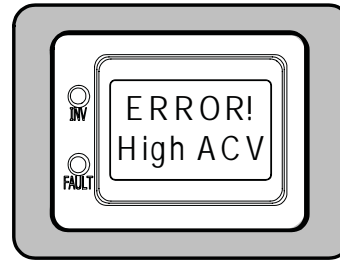

Figure 5-15, High Volts AC Fault

- **High Volts AC** - This fault causes the charger to be disabled because a very high AC voltage (>125 VAC) has been detected on the AC input.



Remedy: Remove all AC power from the inverter's AC input for at least 15 minutes to automatically restart this fault; ensure only 120VAC power is connected to each of the inverter's AC inputs. Check and correct the high voltage problem from the source.

Dead Bat appears on the LCD and the FAULT (red) LED is on. The INV (green) LED's is off.

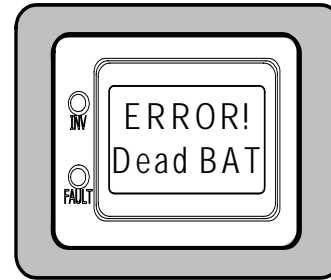

Figure 5-16, Dead Battery Charge Fault

- **Dead Battery Charge** - This fault has detected a very discharged battery bank or a battery bank that is disconnected from the inverter. The unit is attempting to enter the charge mode, but has detected less than 7 volts (12-volt models), 14 volts (for 24-volt models) or 28 volts (for 48-volt models) on the battery bank. This fault will continue until current is able to flow into the battery from the battery charger. Once this happens, the fault will automatically restart.



Remedy: Check the DC voltage on the inverter's DC terminals and compare it with the DC voltage on the battery bank, these two voltages should be very close (<0.5 VDC difference). If not, check to ensure all connections are tight and the fuse/circuit breaker between the inverter and battery bank is good.

Backfeed appears in the LCD and the FAULT (red) LED is on and the INV (green) LED is off

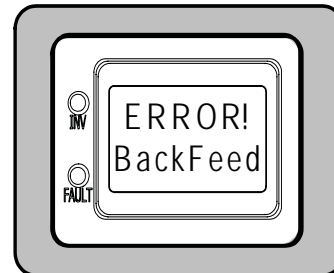

Figure 5-17, BackFeed Fault

- **BackFeed** - This fault message causes the inverter to shutdown because AC voltage from an external AC source has been detected on the inverters AC output. When the unit shuts down because of this fault condition, an inverter reset will be required to resume operation (see section 6.2 to reset the inverter).

FETOverld appears on the LCD and the FAULT (red) LED is on. The INV (green) LED's is off.

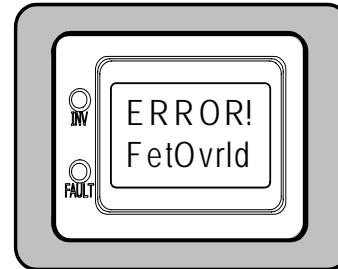

Figure 5-18, FET Overload Fault

- **FET Overload** - This fault message indicates the inverter/charger has shut down because the internal FET's (Field Effect Transistor's) have quickly exceeded a safe operating temperature. When the FET's have cooled, the unit will require a manual restart to resume operation.



Remedy: If the fault continues to occur, disconnect all the inverter's AC output wires and reset the inverter (see section 6.2). If this fault does not clear after doing a reset, the inverter may require service.

CB3 appears on the LCD and the FAULT (red) LED is on. The INV (green) LED's is off.

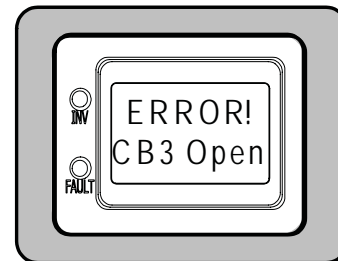

Figure 5-19, Breaker Tripped Fault

- **Breaker Tripped** - The inverter has detected that the AC input breaker on the inverter/charger has opened due to excess current flow thru the inverter to the AC loads.



Remedy: After reducing the AC loads, push in the inverter's AC input circuit breaker to reset and resume operation.



Info: While in charger mode, the inverter's AC input breaker could nuisance trip if the loads on the inverter's AC HOT OUT 1 exceed the current rating of this circuit breaker.

DC Overld appears on the LCD and the FAULT (red) LED is on. The PWR (green), CHG (green) and INV (green) LED's are off.

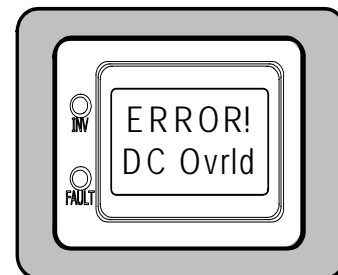

Figure 5-20, DC Overload Fault

- **DC Overld** - This fault causes the inverter to shutdown to protect internal power components and may be caused by an excessive AC load. If the overload condition lasts for less than 10 seconds, the unit will automatically restart and resume operation. However, if the overcurrent condition occurs more than 10 seconds, the unit will shut down and will require a manual restart.



Remedy: This fault usually occurs because the connected AC loads are larger than the inverter's output capacity, there is a wiring short on the AC output or the wires are incorrectly wired. Once the AC loads are reduced or the output wiring is corrected; manually restart the inverter to resume operation. If this fault condition continues after all these recommendation, perform a inverter reset (see section 6.2).

Operation

"#" - A pound/number sign appears on the bottomline of the remote. The FAULT (red) light is on and the INV (green) is off.

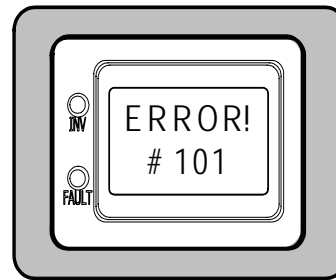

Figure 5-21, Unknown Fault

- # - When a number appears in the second line of the remote it means the remote doesn't know what fault the inverter is reporting.



Remedy - Contact Magnum Technical Support at 425-253-8833 for help with this fault. *note: the numbers in the display above are just placeholders.*

No Comm appears in the LCD; all LED's are off.

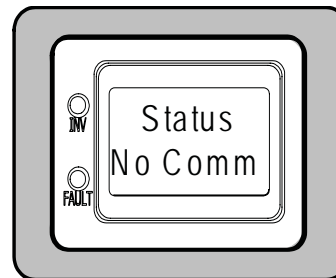

Figure 5-22, No Comm

- **No Comm** - The remote is not receiving any information from the inverter

Relay appears on the LCD and the FAULT (red) LED is on. The INV (green) LED's is off.

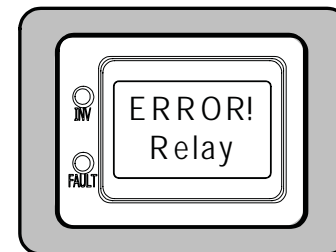

Figure 5-23, Internal Relay Fault

- **Relay** - The internal transfer relay is not closing even though the inverter is charge mode. Please call Magnum Technical Support.

Selco Op appears on the LCD and the FAULT (red) LED is on. The INV (green) LED's is off.

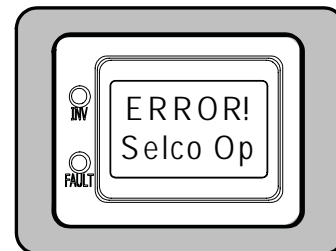

Figure 5-24, Selco Op Fault

- **Selco Op** - This fault message is displayed when the TCO (Temperature Cut-Out) opens and causes the inverter to shutdown to protect the internal power transformer from damage. When the TCO has cooled down, the inverter will automatically restart and resume operation.



Remedy - If this fault occurs while inverting, reduce load on the inverter. If it occurs while charging, turn down the Charge Rate. If it occurs often ensure the inverter has adequate ventilation and the internal cooling fans are operational.

Stak CLK appears on the LCD and the FAULT (red) LED is on. The INV (green) LED's is off.



Figure 5-25, StackClock Fault

5.3.3.3 Stacking Fault Messages – A fault condition may occur when two inverters are stacked in series - using the stacking interface to provide 120/240VAC output - that is not possible on a single inverter installation. Refer to the following fault messages to help troubleshoot the inverters.

- **StackClock Fault** - There is a stacker cable problem or one inverter is losing synchronization with the other inverter.



Remedy: 1. Ensure you are using a Magnum Stacking Cable (this is not a telephone/data cable, this is a custom made cable). 2. Inspect the stacker cable and reconnect at both ends (listen and make sure you hear an audible “click” from the connectors at both inverters).



Info: This fault has been known to occur when a Magnum Energy accessory is plugged into the Stack Port, but the installation is not using multiple inverters in a stacked configuration. If this occurs, perform an inverter reset (see section 6.2).

StakMode appears on the LCD and the FAULT (red) LED is on. The INV (green) LED's is off.

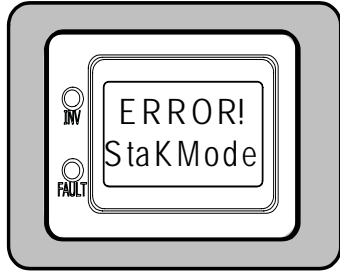

Figure 5-26, Stack Mode Fault

- **Stack Mode Fault** - This unit has detected a problem with the “other” stacked inverter, check that unit for a fault condition.



Remedy: This fault will automatically clear when the fault with the other inverter is corrected.

StkPhasL appears on the LCD and the FAULT (red) LED is on. The INV (green) LED's is off.

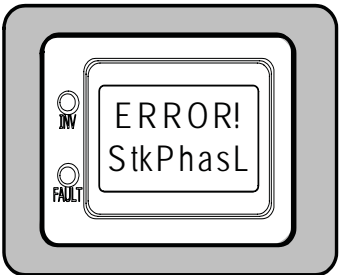

Figure 5-27, StackPhase Fault

- **Stack Phase Fault** - 1.The AC input wiring is incorrect; or 2.One phase was lost from the AC input source; or 3.One of the inverter’s internal transfer relay is bad; or 4.The inverter’s AC input circuit breaker may be open.



Remedy: If this fault doesn’t clear after checking these four recommendations; perform an inverter reset (see section 6.2).

Operation

5.3.3.4 Internal Fault Messages - The inverter continually monitors several internal components. If an condition inside the inverter occurs that does not allow proper operation, the inverter will shutdown to help protect itself. To clear these "internal" type of faults, the inverter will require an inverter reset.



Remedy: Perform an inverter reset; see section 6-2. After resetting the inverter, press the ON/OFF INVERTER pushbutton to turn the inverter on and verify the fault has cleared. If the "internal" fault remains, the inverter may require repair at an Authorized service facility.

Bridge appears on the LCD and the FAULT (red) LED is on. The INV (green) LED's is off.

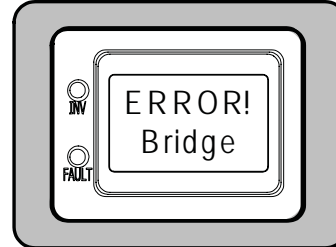

Figure 5-28, Internal Bridge Fault

- **Bridge** - This fault message displays and the inverter shuts down because the internal power-bridge protection circuit has been activated.

Charger appears on the LCD and the FAULT (red) LED is on. The INV (green) LED's is off.

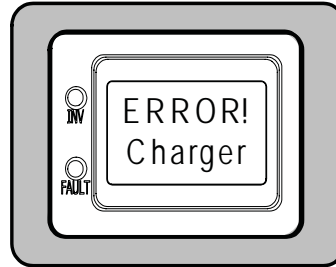

Figure 5-29, Internal Charger Fault

- **Charger** - This fault message displays and the inverter shuts down because the internal charger protection circuit has been activate

NTC Snsr appears on the LCD and the FAULT (red) LED is on. The INV (green) LED's is off.

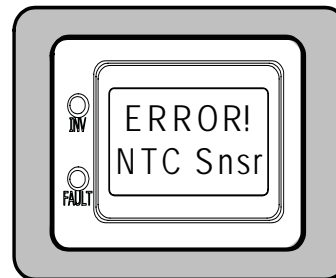

Figure 5-30, Internal NTC Fault

- **NTC Snsr** - This fault message displays and the inverter shuts down because the internal NTC (temperature sensor) circuit has been activated.

5.3.4 LED Indicator Guide

The remote provides the following LED's; use them along with the LCD display to determine the operating status.

Table 5.1, LED Indicator Guide

LED	Status	Meaning
INV (green)	OFF	1. Inverter is disabled; or 2. Remote is in Power Saver mode - press any button to activate LED's
	ON	Inverter is enabled - 1. Supplying AC power on the output; or 2. In standby (if both INV and CHG LED's are on); the inverter will automatically supply AC power to the loads if shore or generator power is lost.
	BLINKING	Inverter is in search mode (the AC load is below the <i>SETUP: 01 Search Watts</i> setting).
FAULT (red)	OFF	Normal operation.
	ON	A fault condition has been detected, check the LCD display to find and correct the cause.

Operation

6.0 Troubleshooting

The remote may not be functioning correctly, use the following table to help find a solution.

Table 6.1, Remote Troubleshooting

Symptom	Possible Cause	Solution
LCD text display is locked-up, pushing any pushbutton has no response - may show "revision" or "connecting".	RJ11 connections on communication cable are not making a good connection	Reset remote: 1) disconnect remote cable from inverter for 5 seconds and reconnect; 2) check RJ11 cable connection on back of remote (see figure 2-2). <u>Important:</u> ensure the RJ11 connector is pushed into the correct port; you should feel/ hear "click" when the connection is made.
	Remote not getting sufficient power from inverter.	Ensure inverter batteries are connected and inverter is operating correctly; inverter should be able to invert and power AC loads from batteries (ensure no AC power is connected to the inverter AC inputs).
LEDs and backlight are off.	Remote is in Power Saver mode.	Press any button to reactivate remote (or turn Power Saver mode Off).
Remote is non-functional (no lights, no text on LCD display and no response when pressing any pushbutton).	Communication cable bad or not correctly connected to remote port on inverter.	Check communications cable from inverter to remote; ensure: 1) it is connected to the REMOTE port, 2) the correct communications cable is used (a 4-conductor telephone cable may be substituted to determine if cable is good).
	Inverter is not connected to batteries.	Ensure inverter batteries are connected and inverter is operating correctly without any AC power connected (can invert and power AC loads from batteries).

6.1 Troubleshooting Tips -

6.1.1 Inverter problems:

- Inverter turned on, green led on inverter blinking, no output: Inverter is in search mode. Either defeat search mode - if not needed - or turn on loads greater than the Search Watts setting.

6.1.2 Charger problems:

- **Unit won't transfer to charge mode with AC applied:** Measure the input AC voltage, it should be 120VAC +/- 20 VAC; 230 or 240 VAC +/- 40VAC also check that VAC dropout setting on the remote is 80 VAC(for NA models) or less.

- **Transfer relay closes then opens and continues to cycle:** AC voltage is too low, or has transients that drop the AC voltage momentarily. Change the VAC Dropout setting to 60 VAC and check for improvements. If the cycling continues, back off the *Charge Rate* from 100% to 10%.

This cycling may also be caused if the AC output of the inverter is connected to the inverter's AC input, check for proper input and output AC wiring. Please check the remote for indication of a fault.

- **Charger not charging even though charge LED is on steady and the unit says "Charging":** Full charge rates are not obtained in "Charging" mode, only after this mode changes to "Bulk Charging", "Absorb Charging" or "Float Charging" modes.

- **Charger not charging even though charge LED is on steady and the unit says "Bulk Charging" (or "Absorb Charging"):** Check the DC amps meter, and DC voltmeter on the ME-MR display, it should be 80% or more of rated charge current if the battery voltage is under 14.0 VDC (28.0 VDC on 24-volt models or 48.0 VDC for 48-volt models). If not, check the *Charge Rate* setting and verify the setting is 80% or greater. Still low charge rate? Check the *Shore Amps* setting to verify setting. If no AC loads are being "passed thru" the inverter, the *Shore Amps* setting must be 15 amps (25 amps for 3kW unit) or greater, to receive full charge rate.

- **Charger says "Float Charging" not "Bulk Charging" when the AC is first plugged in:** Check DC voltmeter on the ME-MR display, if the battery is over 13.0 VDC (26.0 VDC for 24-volt models or 52.0 VDC for 48-volt models) then the battery was already charged and the charger automatically goes to "Float Charging" to keep from overcharging the batteries.

- **Charge amps are lower than expected, or is 0 amps DC:** Measure input AC voltage and increase if the input voltage is under 90 VAC. The charge rate is reduced to try and keep the input voltage above 90 VAC; also check the *Shore Max* and *Charger Rate* settings to determine if the current is being limited.

- **Charger output voltage is higher than expected:** Check the Battery Temperature Sensor (BTS) temperature. If the BTS is installed, the charge voltage settings will increase if the temperature around the BTS is below 77° F (25° C) and decrease if the temperature around the BTS is higher than 77° F (25° C).

Operation

6.2 Performing an Inverter Reset

Press and hold the Power ON/OFF pushbutton (see figure 6-1) for approximately fifteen (15) seconds until the Charging/Inverting Status LED comes on and flashes rapidly; once the rapid flashing has begun, release the Power ON/OFF pushbutton. The Status LED will go off after the pushbutton is released.

After the inverter reset is completed, press the ON/OFF pushbutton to turn the inverter ON.

Some older inverter models do not allow an inverter reset, if the inverter reset fails, you will need to power-down the inverter using the procedure below. In either case, if an "internal fault" does not clear, the inverter will require repair at an authorized service facility.



Info: The Power ON/OFF pushbutton is a small momentary type switch which operates by lightly pressing and releasing.



Info: All adjustable inverter/charger settings in the ME-MR (including item in *SETUP: 01 Shore* thru *SETUP: 08 Power Save*) are saved in non-volatile memory and are preserved until changed - even if an inverter reset is performed or if all power to the remote or inverter is removed.

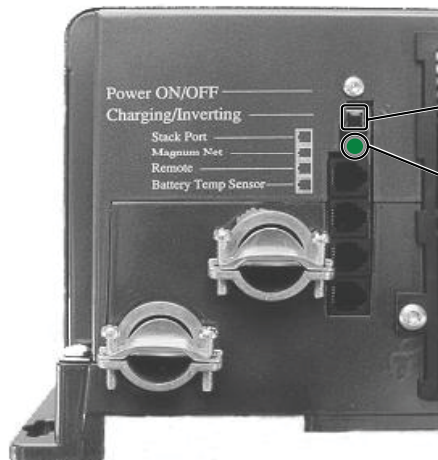

1. Press and hold the Power ON/OFF push-button for 15 seconds

2. Watch the Charging/Inverting Status LED, after approximately 1 seconds it should come on and flash rapidly to indicate the inverter has reset. The Status LED will go off after the pushbutton is released.

Figure 6-1, Performing an Inverter Reset

6.3 Powering-down the Inverter

Perform the following steps to power-down the inverter:

1. Remove all AC power (utility or generator power) to the inverter.
2. Disconnect the positive battery cable to the inverter.
3. Ensure the inverter and remote control are disconnected from all AC and DC power (the remote display will be blank).

After the inverter has been disconnected from all power for 30 seconds, reconnect the positive battery cable and resume operation.



Info: There may be a momentary spark when the positive battery cable is connected to the inverter's terminal; this is normal and indicates that the inverter's internal capacitors are being charged.

7.0 Limited Warranty

Magnum Energy, Inc., warrants the ME-MR remote control to be free from defects in material and workmanship that result in product failure during normal usage, according to the following terms and conditions:

1. The limited warranty for this product extends for a maximum of 24 months from the product's original date of purchase; or for the same period as the connected Magnum Energy inverter if the inverter and remote are newly installed at the same time up to a maximum of 36 months.
2. The limited warranty extends to the original purchaser of the product and is not assignable or transferable to any subsequent purchaser.
3. During the limited warranty period, Magnum Energy will repair, or replace at Magnum Energy's option, any defective parts, or any parts that will not properly operate for their intended use with factory new or rebuilt replacement items if such repair or replacement is needed because of product malfunction or failure during normal usage. The limited warranty does not cover defects in appearance, cosmetic, decorative or structural parts or any non-operative parts. Magnum Energy's limit of liability under the limited warranty shall be the actual cash value of the product at the time the original purchaser returns the product for repair, determined by the price paid by the original purchaser. Magnum Energy shall not be liable for any other losses or damages.
4. Upon request from Magnum Energy, the original purchaser must prove the product's original date of purchase by a dated bill of sale, itemized receipt.
5. The original purchaser shall return the product prepaid to Magnum Energy in Everett, WA. After the completion of service under this limited warranty, Magnum Energy will return the product prepaid to the original purchaser via a Magnum-selected non-expedited surface freight within the contiguous United States and Canada; this excludes Alaska and Hawaii.
6. If Magnum repairs or replaces a product, its warranty continues for the remaining portion of the original warranty period or 90 days from the date of the return shipment to the original purchaser, whichever is greater. All replaced products and parts removed from repaired products become the property of Magnum Energy.
7. This limited warranty is voided if:
 - the product has been modified without authorization,
 - the serial number has been altered or removed,
 - the product has been damaged through abuse, neglect, accident, high voltage or corrosion.
 - the product was not installed and operated according to the owner's manual.

BEFORE RETURNING ANY UNIT, CONTACT MAGNUM ENERGY FOR A RETURN MATERIAL AUTHORIZATION (RMA) NUMBER.



Magnum Energy, Inc.
2211 West Casino Rd.
Everett, WA 98204
Phone: 425.353.8833
Fax: 425.353.8390
Web: www.magnumenergy.com