

Installing the Enphase AC Combiner Box

To install the Enphase™ AC Combiner Box, read and follow all warnings and instructions in this Guide and in the *Enphase Envoy-S Installation and Operation Manual* at: enphase.com/support. Safety warnings are listed on the back of this guide. If you do not fully understand any of the concepts, terminology, or hazards outlined in these instructions, refer installation to a qualified electrician or installer. These instructions are not meant to be a complete explanation of a renewable energy system. All installations must comply with national and local electrical codes. Professional installation is recommended.

The AC Combiner Box is an outdoor-rated, NRTL-certified NEMA type 3R, polycarbonate enclosure containing an Enphase™ Envoy-S, circuit breakers, and wiring for Envoy-S connections. The AC Combiner Box combines up to three AC branch circuits of Enphase Microinverters.

How It Works

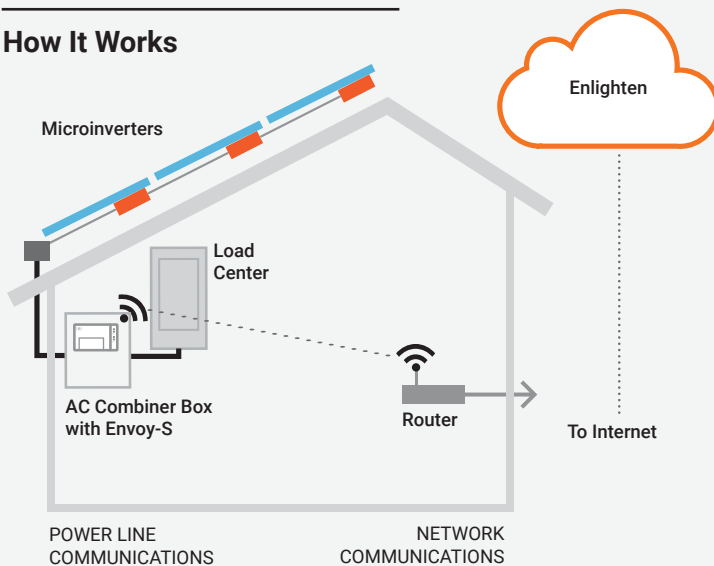

Envoy-S Display and Controls

Track system installation progress with the **Enphase Installer Toolkit** mobile app. The LEDs on the Envoy-S are solid green when a function is enabled or performing as expected, flashing when an operation is in progress, or solid amber when troubleshooting with Installer Toolkit is required. For a legend of all LED states, see *Troubleshooting*

- Network Communications LED**
Green when Envoy-S is connected to Enlighten.
- AP Mode LED**
Green when Envoy's AP Wi-Fi network is available.
- AP Mode Button**
Press to enable Envoy's AP Mode for connecting with a mobile device. Hold for 5 seconds to start WPS connection to a router.
- Power Production LED**
Green when microinverters are producing power.
- Device Communications LED**
Green when microinverters are communicating with Envoy-S.
- Device Scan Button**
Press to start/stop 15 minute scan for microinverters over the power line.



Enphase Installer Toolkit mobile app

PREPARATION



- A) Download the Enphase Installer Toolkit mobile app and open it to log in to your Enlighten account. With this app, you can connect to the Envoy-S to track system installation progress. To download, go to enphase.com/toolkit or scan the QR code at right.
- B) Check the box for the following items:
 - Enphase AC Combiner Box with Envoy-S
 - Ferrite bead to attach to your Ethernet Cable, if used
- C) Make sure you have the following **required** items:
 - Plan to use screwdriver, pliers, torque wrench, etc.
 - Provide overcurrent protection in accordance with NFPA 70-2014, §705.12(D).
 - Provide suitable mounting hardware: use screws that are long enough to secure the unit to the vertical mounting surface
 - Use copper conductors rated for wet locations and sized to meet local code requirements and voltage drop/rise considerations: 12-6 AWG copper for branch inputs.
 - Use only UL Listed rain-tight or wet location hubs for wire entry into the enclosure.
- D) Make sure you have the following **optional** items, if needed:
 - Two (2) consumption metering split-core CTs (order CT-200-SPLIT)
 - Enphase Mobile Connect modem (order CELLMODEM-01)
 - Ethernet over power line communication (PLC) bridge with Ethernet cables (order EPLC-01)
 - Ethernet cable: 802.3, Cat5E or Cat6, unshielded twisted pair (UTP). Do not use shielded twisted pair (STP) cable.
- E) Check that there is enough space in the switchboard to install CTs. Do not install the CTs in a panel where they exceed 75% of the wiring space of any cross-sectional area within the panel.
- F) Decide how to connect the Envoy-S to the Internet: Wi-Fi, an Enphase Mobile Connect modem, or Ethernet.
- G) Install the PV modules and microinverters as directed by the installation manuals.
- H) Create a paper installation map to record microinverter serial numbers and positions in the array. You will scan this map later using Installer Toolkit and your mobile device.
 - Peel the removable serial number label from each microinverter and affix it to the respective location on the paper installation map.
 - Write the Envoy-S serial number on the paper installation map. Later, you will need to enter this number in Installer Toolkit. You can type it in manually or scan the label on the inside of the AC Combiner box door.
 - Always keep a copy of the installation map for your records and to upload to Enlighten later.

Note: If needed, you can find an installation map at the back of any *Enphase Microinverter Quick Install Guide*.

INSTALLATION

1 Choose a location for the AC Combiner Box

- A) Install the AC Combiner Box in a readily accessible location, at least four feet (1.2 meters) off the ground.
- B) Consider the dimensions of the combiner box, easy access, box height, and length of cable when selecting the location. Do not block the vents. The box is rainproof but not watertight.

2 Prepare the AC Combiner Box

- A) If needed, reposition the mounting feet. You can adjust each of the four mounting feet to several different positions. Adjust as desired for the mounting location.
- B) Open the enclosure door. Pinch the top of the hinge rod using a needle-nosed pliers. Slide the door up and away to remove it. Set the door aside for later reattachment.
- C) Mount the box on a vertical surface, using supplied washers to protect the feet.
- D) Remove the clear plastic deadfront and keep the screws and washers in a safe place (for example, inside the removed enclosure door).
- E) Locate and remove the Spare Parts and XA-SLOT bags.



Foot mounting on back of unit



Foot mounted horizontally



Mounting foot



Foot mounting screw

Foot mounted at an angle



Foot mounted vertically



3 Remove an Unused Circuit Breaker (optional)

The combiner includes three 20 A, 2-pole circuit breakers for combining inputs. If required by local jurisdiction, you can remove one 2-pole breaker if there are only two branch circuits.

If you do not need to remove a circuit breaker, skip this step.

- A) Use a straight blade screwdriver to completely loosen the busbar side of the Line 1 and Line 2 terminal blocks (gray).
- B) Remove any load wire(s) on the breaker you want to remove.
- C) Loosen the busbar lug(s) of only the breaker you want to remove.
- D) Release the DIN rail locking tabs of all breakers.
- E) Rock the breaker/busbar assembly to the left to release it from the DIN rail, and remove the breaker.
- F) Rock the breakers back to the right so they are seated back on the DIN Rail.
- G) Lock all of the breaker locking tabs.
- H) Tighten the busbar side of the Line 1 and Line 2 terminal blocks (gray) to 14 in-lbs (1.6 Nm).
- I) Verify that all busbar connections are tight.
- J) Install the blanking plate onto the dead front over the location of the removed breaker using the screws provided. Every AC Combiner Box comes with an XA-SLOT spares kit with two screws and a blanking plate.

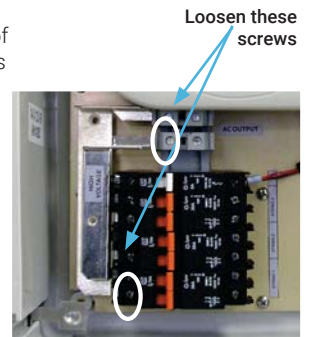

Loosen these screws



Locking tabs

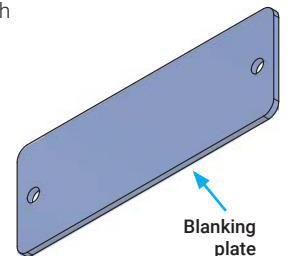

Blanking plate

4 Drill Hole(s) to Accept Conduit



Warning! Do not drill conduit holes on the top of the box or at any location that allows moisture ingress. This voids the warranty for the combiner box and the Envoy-S.

- A) A label on the outside of the combiner box indicates the best location to make a hole or holes to accept conduit fittings. Locate this label.

Best Practice: Use a stepped drill bit for making the conduit holes. Using a hole saw may crack the plastic housing. As an alternative, use a sharp chassis punch with caution. Drill only at the label location. Do not drill a hole in any other location on the box.

Note: The label template has three holes, but most applications require only two.

- B) Use the provided label as a template for typical conduit placement. The center of the holes on the label are marked with a "+".
- C) Use a snap punch or other type of center punch to prevent the drill from wandering. Drill a pilot hole with a smaller drill before using a step drill bit.
- D) Remove the label after drilling.
- E) Use only UL Listed rain-tight or wet location hubs for wire entry into the enclosure.



Warning! Observe bend radius requirements when routing wires.

5 Wire the Output Connections

- A) Use conductors sized per local code requirements, 12 to 4 AWG copper conductors for combined output, taking into consideration the voltage drop/rise and upstream breaker or fuse.
- B) The two DIN rail terminal blocks above the circuit breakers are the output connections. Install the black wire into the lower terminal block and the red into the upper terminal block.
- C) Torque to 14 in-lbs (1.6 Nm).
- D) Connect the neutral (white) to the neutral busbar.
- E) Connect the ground (green or green/yellow) to the "Ground" busbar and torque to 45 in-lbs (5 Nm).

6 Wire Inputs from the AC Branch Circuits

The combiner comes with three 20A circuit breakers (16A continuous) to which you must wire the microinverter AC branch circuits.

- A) Use copper conductors sized to meet local code requirements and voltage drop/rise considerations: 12 to 6 AWG copper for branch inputs.
- B) Bring in the wires from each AC branch circuit.
- C) Connect the neutral wires (white) to the neutral bus and the ground wires (green or green/yellow) to the ground bus. Torque to 45 in-lbs (5 Nm).
- D) Connect L1 and L2 (usually one black and one red) from each AC branch circuit to the circuit breakers.
- E) Torque to 20 in-lbs (2.4 Nm).

Best Practice: L1 and L2 should be wired as shown, with L1 and L2 alternating.

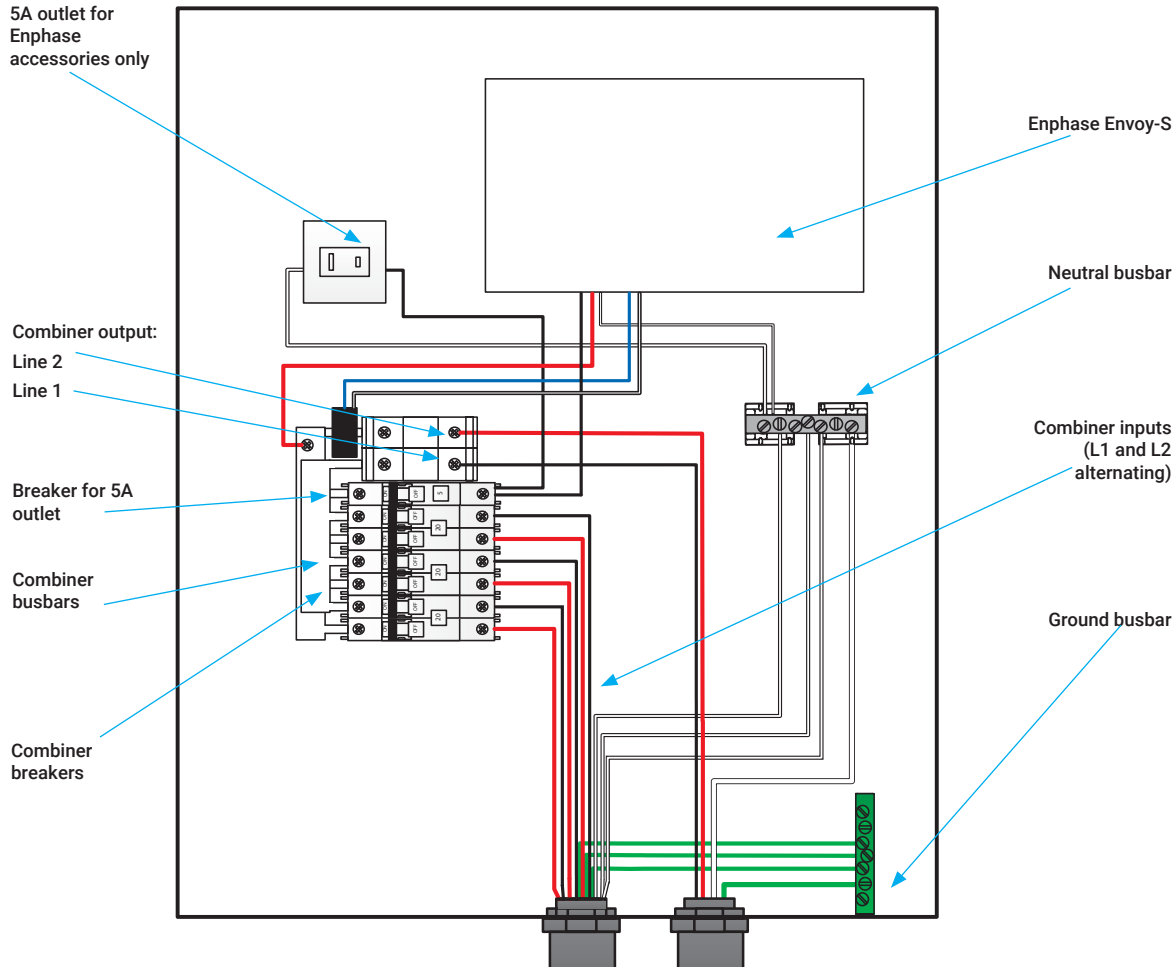

7 Install CTs for Consumption Metering (optional)

The Envoy-S inside the AC Combiner Box is pre-wired at the terminal blocks for power and production metering connections. One solid-core current transformer (CT) is provided for revenue grade production metering. You can install two optional split-core CTs to provide consumption metering. To do this, you must create a protected route using conduit for the CT wires from the main load center to the Envoy-S. If you need to extend the wires, refer to the *Enphase Envoy-S Installation and Operation Manual* at: enphase.com/support.

Note: Because of variance in load center design and main power feed, there may not always be enough space to install consumption metering CTs.

- A) Make sure that the main load center wires are de-energized until you have secured the CT wires in the terminal blocks.
- B) Locate the screw on the left side of the terminal block door, loosen it with a screwdriver to unlock, and flip open the terminal block door.
- C) Before running the CT wires through the conduit, use colored tape to mark one of the CTs and the free end of its wires.
- D) For the marked CT wires, connect the white wire to "IA•" and the blue wire to "IA".
- E) For the unmarked CT wires, connect the white wire to "IB•" and the blue wire to "IB".
- F) Tighten all connections to 5 in-lbs.
- G) Install the marked CT on the load center feed wire Line 1 (matching the Combiner output terminal Line 1, bottom terminal) with the CT arrow pointing toward the load.
- H) Install the unmarked CT on the load center feed wire Line 2 (matching the Combiner output terminal Line 2, upper terminal) with the CT arrow pointing toward the load.



DANGER!

Risk of electric shock. Always de-energize the load center before beginning wiring.



DANGER! Risk of electrocution! Do not install CTs when current is flowing in the sensed circuit. Always install CT wires in the terminal blocks before energizing the sensed circuit.

Notes: To properly measure power and energy, CT inputs A and B must align with the respective voltage inputs A and B. For example, make sure both CT input A and voltage input A are the same line phases.

When installing CTs, it is important to match CT and sense voltage phases. Be sure to consistently identify and match the two AC lines at two points: the main load center feed and the Envoy. Wire colors (typically black and red) may not always consistently identify Lines 1 and 2. If in doubt, use a multimeter to check.

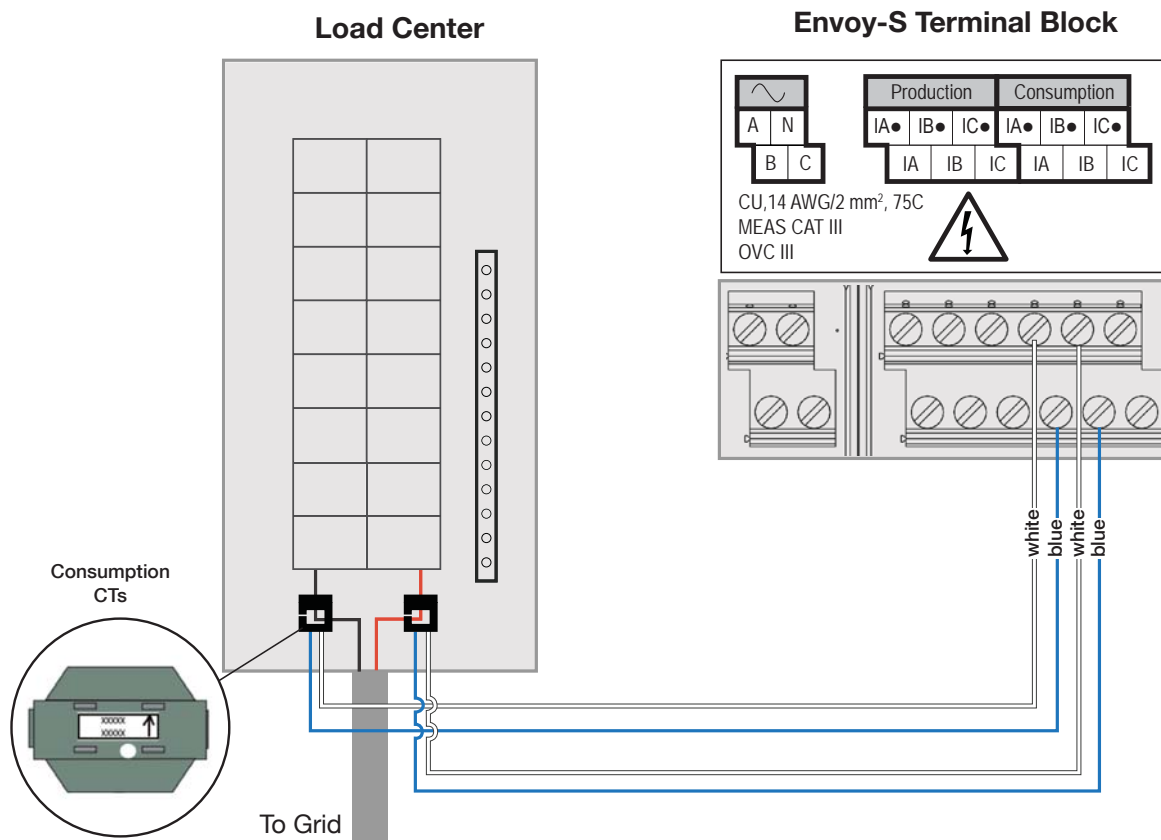

8 Energize the Envoy-S

- Re-install the clear plastic deadfront. Start all of the screws, but do not completely tighten them. Once all screws are partially tightened, go back and tighten each one completely.
- Close the terminal block door, and secure it with the screw.
- Reinstall the AC Combiner Box door.
- Turn on the circuit feeding the combiner box.
- All four LEDs flash amber during boot up (approximately 3 minutes). When boot up is complete, the Device Communications LED  lights solid amber, indicating that microinverters are not yet detected.

9 Detect Microinverters

Use one of the following methods to detect microinverters.

Method A // Provision microinverters with Installer Toolkit

Use the Installer Toolkit mobile app to configure the Envoy-S with the serial numbers of the installed microinverters.

- Launch Installer Toolkit and tap **View Systems**.
- Select the system you are working with, or tap **[+]** to add a system.
- Connect to the Envoy-S with your mobile device as described in the note on top of the next column.
- Return to Installer Toolkit. If the serial number for the Envoy-S you are installing is not displayed on the System Overview screen, tap the **[+]** next to the word "Envoys". When the app displays the serial number of the Envoy-S, tap it to add it to the system.
- Create the arrays and scan the serial numbers from the installation map as instructed by the *Installer Toolkit Operation Manual* at enphase.com/support.
- Tap the **Connect** button. This provisions the scanned microinverters on the Envoy-S.
- When prompted, confirm the number of microinverters that you installed.
- If your system is in Hawaii or in another region that does not use the **Factory-Installed Grid Profile**, select and apply a grid profile to the microinverters.

The Device Communications LED  lights solid green if all of the provisioned devices are communicating or solid amber if any devices are not communicating.

Method B // Discover microinverters with Installer Toolkit

Use the Installer Toolkit mobile app to set the number of microinverters the Envoy-S should search for on the power line.

- Connect to the Envoy-S with your mobile device as described in the note on top of the next column.
- Launch Installer Toolkit and tap **Connect to an Envoy**.
- When prompted, enter the number of microinverters that you installed.
- If your system is in Hawaii or in another region that does not use the **Factory-Installed Grid Profile**, select and apply a grid profile to the microinverters.
- When prompted to start a device scan, tap **OK**.

The Device Communications LED  flashes green while scanning. It lights solid green when all of the microinverters you installed are communicating or solid amber if any devices are not communicating.

Note: Connecting to Envoy-S with a Mobile Device

The Envoy's AP (Access Point) Wi-Fi network allows you to connect your mobile device to the Envoy-S. The AP Mode LED  lights solid green when the network is available.

- On the Envoy-S, if the AP Mode LED is not lit, press the AP Mode button.
- On your mobile device, go to Settings and join the Wi-Fi network "Envoy_nnnnnn" (where "nnnnnn" represents the final six digits of the Envoy-S serial number).



While your mobile device is connected to the Envoy's AP Wi-Fi Network it cannot communicate with the Internet. If you need to communicate with the Internet and Enlighten, disconnect your mobile device from the Envoy's AP Wi-Fi Network.

Method C // Discover microinverters with the Envoy-S

If you are not using the Installer Toolkit app, press the Device Scan button on the Envoy-S. With this method, the Envoy-S searches the power line for 15 minutes, but does not know how many microinverters it should discover.

The Device Communications LED  flashes green for 15 minutes while scanning. At the end of the scan, it lights solid green if at least one microinverter was discovered or solid amber if no microinverters were discovered (or if any discovered microinverter stops communicating).



With all methods

If the Device Communications LED  remains solid amber, see *Troubleshooting* .

10 Verify System Configuration

While still connected to the Envoy-S with Installer Toolkit, check the Envoy Overview screen for the following:

- Confirm that the expected number of devices are detected and communicating.
- If you selected a grid profile, check the Envoy Overview screen to make sure the new profile is set on all the microinverters. This may take up to 5 minutes for a typical system.
- Set up metering:
 - If there is a check next to **Production Meter**, the production meter is enabled. If a gear  is shown, you must enable the meter:
 - Tap **Production Meter** and follow the on-screen instructions to enable the Production Meter.
 - If you installed consumption metering CTs, tap the **>** to the right of **Consumption Meter**.
 - Based on where you installed the consumption CT, indicate whether the circuit that passes through the consumption CT includes:
 - Load with solar production (also known as net) or
 - Load only (also known as total or gross), for example, in the case of a line-side tap.
 - Tap **Enable Consumption Meter**.
 - Return to the Overview screen and verify the meter reading(s).

If you used Installer Toolkit to detect microinverters, the Power Production LED  lights solid green when all expected microinverters are producing power. If you did not use Installer Toolkit, it lights solid green if all communicating microinverters are producing power. It flashes green when microinverters are upgrading. Check Installer Toolkit for production status details. If the Power Production LED  remains solid amber, see *Troubleshooting* .

11 Connect to Enlighten

This section describes using the Envoy-S integrated Wi-Fi or the Mobile Connect modem. For information about using Ethernet cable or PLC bridges, refer to the *Enphase Envoy-S Installation and Operation Manual* at enphase.com/support.



WARNING: Do not remove power from the Envoy-S if the LEDs are flashing green. This indicates that a software upgrade is in progress.



Method A // Integrated Wi-Fi

Requires a wireless router with an Internet connection.

- On the Envoy-S, verify that no Ethernet cable is plugged into the RJ45 port.
- If the router supports WPS, press and hold the WPS button on the wireless router for a few seconds. On most routers, a WPS indicator begins flashing.
- If you are using the Installer Toolkit mobile app, tap the **Network** button, tap **Wi-Fi**, and then tap your network from the list of available networks. If the wireless router does not support WPS, you may be prompted to enter a password.



If you are not using the Installer Toolkit mobile app, you can only connect using WPS. Initiate a WPS connection by pressing and holding the AP Mode button for 5 seconds.

The Network Communications LED  begins flashing green. Within three minutes it lights solid green, indicating a successful connection to Enlighten. If the Network Communications LED  remains off or lights solid amber, see *Troubleshooting* .

Method B // Enphase Mobile Connect Modem

(Order CELLMODEM-01 separately)

- Connect the antenna to the connector (marked CELL) on the modem.
- Use the two pop rivets in the deadfront to secure the modem via its mounting tab. For more information, refer to the *Enphase Mobile Connect Installation Guide*.
- Connect the mini-USB cable to the modem and connect the other end of the cable to the Envoy-S. If receiving power from the Envoy-S, the modem power LED lights.

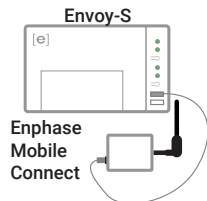

Within three minutes the Network Communications LED  lights solid green, indicating a successful connection to Enlighten. If it remains off or lights solid amber, see *Troubleshooting* in the *Enphase Mobile Connect Installation Guide*.

Method C // Power Line Communication Bridges

(Order EPLC-01 separately)

Requires a broadband router with an Internet connection.

- Plug one of the bridges into the same AC outlet that the Envoy-S is using.
- Place the bead on the cable, near one end, and close the latch.
- Plug the cable end with the ferrite into the Envoy-S Ethernet port, and secure a tie wrap on the cable on each side of the ferrite bead.
- Tighten an additional tie wrap around the ferrite bead.
- Trim any tie wrap excess.
- Plug the other end of the Ethernet cable into the bridge.
- Plug the other bridge into an AC outlet near the broadband router.
- Connect one end of a second Ethernet cable to the second bridge, and connect the other end of the cable into the broadband router.

Within three minutes the Network Communications LED  lights solid green, indicating a successful connection to the Internet and to Enlighten.

12 Send System Summary Report

When you have completed your system setup, you can generate and email a summary report.

- From Installer Toolkit, tap **Done** in the upper-right corner of the screen to disconnect from the Envoy. Installer Toolkit will ask if you want to view a summary report.
- Tap **View Report**. The report displays Envoy-S and system information with a list of microinverter serial numbers, their last power reports, and information about the grid profile applied to the microinverters.
- Tap  to email the report to your office as a record of successful system installation or to the utility for evidence of grid profile settings.

13 Re-torque Connections and Secure the Door

- Turn off power to AC combiner box at the main load center. Verify that all power is removed from the system before attempting any wiring.
- Open the AC Combiner Box door.
- Remove the clear plastic dead front, and keep the screws and washers in a safe place.
- Measure voltage L1 to L2, L1 to N, and L2 to N to make sure there is no voltage present.
- Re-torque all field wiring connections one hour after first torque.



WARNING: Do not skip this step. You must re-torque all field wiring connections after one hour.

- Close and secure the door of the combiner box so that it is protected against moisture and rain.

ACTIVATE MONITORING

Register the Envoy-S in Enlighten (enlighten.enphaseenergy.com).

Method A // If the Envoy-S is associated with a system in Installer Toolkit

- On your mobile device, go to Settings and disconnect from the Envoy's AP Wi-Fi network.
- Return to the Installer Toolkit app and tap the **Sync** button on the System Overview screen.
- When you have access to a computer, log in to Enlighten and select the system name from the Activation List on the dashboard.
- From the activation form, open Array Builder.

If you used Installer Toolkit to build arrays and scan microinverter serial numbers, the array(s) are built—make any necessary adjustments in Array Builder.

If you did NOT use Installer Toolkit to build arrays and scan microinverter serial numbers, create the virtual array in Array Builder using the installation map as your reference. (You may need to wait if the microinverters have not yet reported to Enlighten.)

Method B // If the Envoy-S is NOT associated with a system in Installer Toolkit

- Log into Enlighten and click **Add a New System** from the dashboard.
- Enter the System, Installer, Owner, and Location information.
- Enter the Envoy-S serial number.
- Click **Save** to submit the form.
- After the microinverters have reported to Enlighten, open Array Builder from the activation form, and create the virtual array, using the installation map as your reference.

Troubleshooting

a LED overview

LED	State	Description
All	Flashing amber in unison	The Envoy-S is booting up
	Flashing green sequentially	Software upgrade in progress
Network communications	Solid green	Communicating with Enlighten
	Flashing green	WPS connection in progress, or Envoy-S is attempting to connect to Enlighten
	Solid amber	Local network connection only
	Off	No network connection
AP mode	Solid green	AP mode enabled: Envoy-S Wi-Fi network available
	Off	AP mode disabled: Envoy-S Wi-Fi network unavailable
Power production	Solid green	All communicating microinverters are producing
	Flashing green	Microinverter upgrade in progress
	Solid Amber	At least one microinverter is not producing
	Off	Microinverters are not communicating (low light or night time)
Device communications	Solid Green	All devices are communicating
	Flashing Green	Device scan in progress
	Solid Amber	At least 1 microinverter is not communicating
	Off	Microinverters are not communicating (low light or night time)

b Microinverter detection issues

If the Device Communications LED  lights solid amber, it may be a result of low light levels. If there isn't enough sunlight to power up the microinverters, they can't communicate with the Envoy.

If there is sufficient daylight for the microinverters to power up, the issue may be that the Envoy is having difficulty communicating over the power lines. To troubleshoot this issue:

- Check the Installer Toolkit mobile app to see which microinverters are not communicating.
- Check that the circuit breaker(s) in the AC Combiner Box for the PV array are in the "ON" position.
- Verify that the PV modules are connected to the microinverters.
- Verify the PV module DC voltage is within the allowable range for the microinverter.

c Power production issues

If the Power Production LED  lights solid amber, check the Installer Toolkit mobile app to see which microinverters are not producing:

- If none of the microinverters are producing power, there may be a grid or wiring issue. First, verify that there is proper input voltage and frequency from the utility. Next, check the breaker and wiring, starting at the load center.
- If all of the non-productive microinverters are on the same branch, check the breaker and wiring starting at the junction box for the affected branch.
- If only one or scattered microinverters are not producing power, first check to see that the AC connectors are fully seated in the Engage Cable connectors. Next, check that each module is providing the required startup voltage for the microinverter (22V). A PV module that is failing or that is undersized may not generate enough power for AC conversion.

d Internet connection issues

If you are using Wi-Fi and the Network Communications LED  remains off:

- The WPS connection window may have timed out. Retry the connection steps.
- Make sure that the broadband router is operational by checking that other devices at the site can access the network.
- Be aware that metal enclosures or obstructions impede wireless communication.
- If you cannot see your router or access point in the list on the Envoy, or cannot maintain a connection, it may be necessary to add a wireless repeater to extend the network range.

If you are using Wi-Fi and the Network Communications LED  lights solid amber, make sure that the broadband router is connected to the Internet by checking that other devices at the site can access the Internet.

If you are using the Enphase Mobile Connect modem and the Network Communications LED  remains off or lights solid amber, see Troubleshooting in the *Enphase Mobile Connect Installation Guide*.

For any connection method, you can troubleshoot network issues with the Installer Toolkit mobile app by tapping the **Network** button, then **Diagnostic Tools**.

If you replace the broadband router, configure the Envoy-S Wi-Fi settings for the new Wireless Network Name (SSID) and password, or use the WPS function described in Installation Step 11.

e Loss of AC to a single branch of microinverters

If a single branch of microinverters is not producing, it may indicate loss of AC to the branch.

Using a multi-meter set to AC, refer to the figure below and test for the following values:

- Test point A to test point B. The result should be around 240 VAC.
 - Test point A to test point C. The result should be around 120 VAC.
 - Test point B to test point C. The result should be around 120 VAC.
- If not, there may be a problem with the supply wiring.

- Test point C to the screws on the load-side breaker screws (D). The result should be around 120 VAC.

If not, switch the breaker off and on to reset. If this does not remedy the problem, contact Enphase Customer Support (enphase.com/en-us/support/contact).

f Inoperable Envoy-S (all LEDs off)

If the Envoy-S is not receiving power, all LEDs will be off.

Using a multi-meter set to AC, refer to the figure below and test for the following values:

- Test point A to test point C. The result should be around 120 VAC.
- If not, check the supply wiring.
- Test point C to test point D. The result should be around 120 VAC.
- If not, contact Enphase Customer Support (enphase.com/en-us/support/contact).

g Inoperable Envoy-S and no AC to branch

If a single branch of microinverters is not producing and the Envoy-S LEDs are off, do the following:

Using a multi-meter set to AC, refer to the figure below and test for the following values:

- Test point C to test point E. The result should be around 120 VAC.
- Test point C to test point F. The result should be around 120 VAC.
- Test point C to test point G. The result should be around 120 VAC.
- Test point C to test point H. The result should be around 120 VAC.

If not, there may be a problem with the wiring from the panel.

Test Points

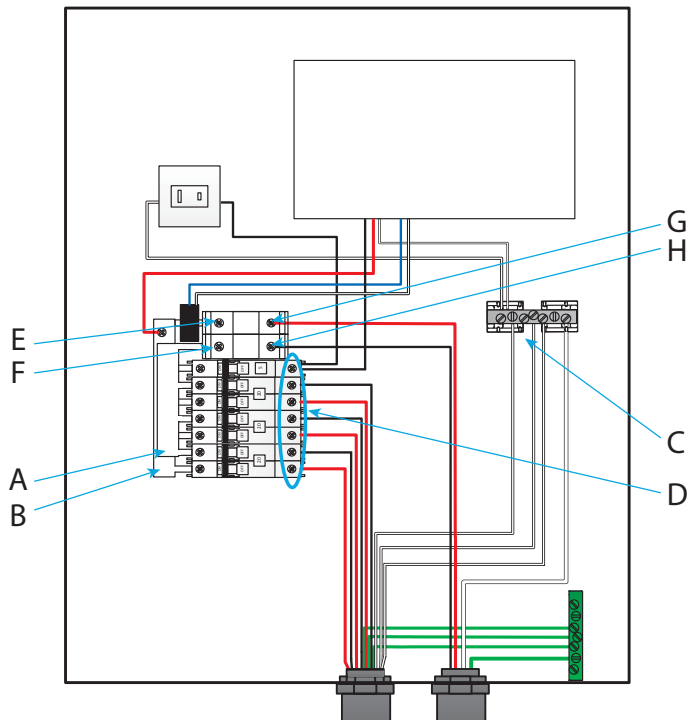



SAFETY

IMPORTANT SAFETY INSTRUCTIONS













SAVE THESE INSTRUCTIONS









This guide contains important instructions that you must follow during installation and maintenance of the AC Combiner Box.

Safety and Advisory Symbols

	DANGER: This indicates a hazardous situation, which if not avoided, will result in death or serious injury.
	WARNING: This indicates a situation where failure to follow instructions may be a safety hazard or cause equipment malfunction. Use extreme caution and follow instructions carefully.
	NOTE: This indicates information particularly important for optimal system operation. Follow instructions carefully.

Safety Instructions

	DANGER: Risk of electric shock. Risk of fire. Do not attempt to repair the Envoy-S; it contains no user-serviceable parts. Tampering with or opening the Envoy-S will void the warranty. Warranty void if cover removed. If the Envoy-S fails, contact Enphase Customer Support for assistance (enphase.com/en-us/support/contact).
	DANGER: Risk of electrocution! Do not install CTs when current flowing in the sensed circuit. Always install CT wires in the terminal blocks before energizing the sensed circuit.
	DANGER: Risk of electric shock. Do not use Enphase equipment in a manner not specified by the manufacturer. Doing so may cause death or injury to persons, or damage to equipment.
	DANGER: Risk of electric shock. Be aware that installation of this equipment includes risk of electric shock. Do not install the AC Combiner Box without first removing AC power from the Enphase System. Disconnect the power coming from the photovoltaics before servicing or installing.
	DANGER: Risk of electric shock. Risk of fire. Only qualified personnel should troubleshoot, install, or replace the AC Combiner Box.
	DANGER: Risk of electric shock. Improper servicing of the combiner box or its components may result in a risk of shock, fire or explosion. To reduce these risks, disconnect all wiring before attempting any maintenance or cleaning.
	DANGER: Risk of electric shock. Always de-energize the AC branch circuit before servicing. Never disconnect the DC connectors under load.
	DANGER: Risk of electric shock. Risk of fire. Only use electrical system components approved for wet locations.
	DANGER: Risk of electric shock. Risk of fire. Ensure that all wiring is correct and that none of the wires are pinched or damaged.
	DANGER: Risk of electric shock. Risk of fire. Do not work alone. Someone should be in the range of your voice or close enough to come to your aid when you work with or near electrical equipment. Remove rings, bracelets, necklaces, watches etc. when working with batteries, photovoltaic modules or other electrical equipment.
	DANGER: Risk of electric shock. Risk of fire. Before making any connections verify that the circuit breakers are in the off position. Double check all wiring before applying power.
	DANGER: Risk of electric shock. Risk of fire. Do not wire unused terminals or terminal blocks on the Envoy-S.
	WARNING: Before installing or using the AC Combiner Box, read all instructions and cautionary markings in the technical description and on the equipment.

	WARNING: Use the circuit breakers in the Enphase AC Combiner Box only for serving Enphase equipment. No other loads are allowed.
	WARNING: This unit is not provided with a GFDI device. This inverter or charge controller must be used with an external GFDI device as required by the Article 690 of the National Electrical Code for the installation location.
	WARNING: This product is intended for operation in an environment having a maximum ambient temperature of 46°C (115°F).
	NOTE: Perform all wiring in accordance with all applicable local electrical codes, with the Canadian Electrical Code, Part I, and with the National Electrical Code (NEC), ANSI/NFPA 70.
	NOTE: Protection against lightning and resulting voltage surge must be in accordance with local standards.
	NOTE: Using unapproved attachments or accessories could result in damage or injury.
	NOTE: Install the AC Combiner Box in the field with 75°C or 90°C copper conductors sized per local code requirements and voltage drop/rise considerations.
	NOTE: Use Class 1 wiring methods for field wiring connections to terminals of a Class 2 circuit. Use only 12 to 6 gauge wire. Select the wire gauge used based on the protection provided by the circuit breakers/fuses. Overcurrent protection must be installed as part of the system installation.
	NOTE: To ensure optimal reliability and to meet warranty requirements, the Enphase AC Combiner Box must be installed according to the instructions in this manual.

FCC Statement: This equipment has been tested and found to comply with the limits for a Class B digital device, pursuant to part 15 of the FCC Rules. These limits are designed to provide reasonable protection against harmful interference in a residential installation. This equipment generates, uses and can radiate radio frequency energy and, if not installed and used in accordance with the instructions, may cause harmful interference to radio communications. However, there is no guarantee that interference will not occur in a particular installation. If this equipment does cause harmful interference to radio or television reception, which can be determined by turning the equipment off and on, you are encouraged to try to correct the interference by one or more of the following measures:

- Reorient or relocate the receiving antenna.
- Increase the separation between the equipment and the receiver.
- Connect the equipment into an outlet on a circuit different from that to which the receiver is connected.
- Consult the dealer or an experienced radio/TV technician for help.

Changes or modifications not expressly approved by the party responsible for compliance may void the user's authority to operate the equipment.

This Class B digital apparatus complies with Industry Canada ICES-003.

