



HiDM Black

HIGH DENSITY MONO PERC MODULE

POWER RANGE: 320 W ~ 330 W

(EQUIVALENT TO 60 CELL FORMAT)

CS1H-320|325|330MS

With Canadian Solar's innovative module technology and Mono-PERC cell technology, we will offer our customers high power modules up to 330 W with enhanced aesthetics appearance. Through maximizing the light absorption area and removing the loss of ribbon resistance, the module efficiency can reach up to 19.57 %.



MORE POWER



Maximize the light absorption area, module efficiency up to 19.57 %



Low NMOT: 43 ± 3 °C
Low temperature coefficient (Pmax): -0.37 % / °C



Better shading tolerance

MORE RELIABLE



Lower hot spot temperature



Minimizes micro-cracks



Heavy snow load up to 5400 Pa,
wind load up to 2400 Pa



linear power output warranty



product warranty on materials and workmanship

MANAGEMENT SYSTEM CERTIFICATES*

ISO 9001:2008 / Quality management system

ISO 14001:2004 / Standards for environmental management system

OHSAS 18001:2007 / International standards for occupational health & safety

PRODUCT CERTIFICATES*

IEC 61215 / IEC 61730: VDE / CE (Expected July 2018)

UL 1703: CSA (Expected August 2018)

* As there are different certification requirements in different markets, please contact your local Canadian Solar sales representative for the specific certificates applicable to the products in the region in which the products are to be used.

CANADIAN SOLAR (USA), INC. is committed to providing high quality solar products, solar system solutions and services to customers around the world. As a leading PV project developer and manufacturer of solar modules with over 26 GW deployed around the world since 2001, Canadian Solar Inc. (NASDAQ: CSIQ) is one of the most bankable solar companies worldwide.

*For detail information, please refer to Installation Manual.

ENGINEERING DRAWING (mm)

Rear View

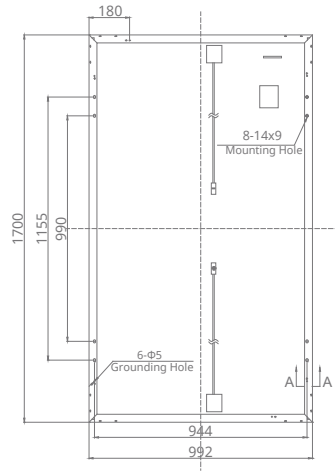

Frame Cross Section A-A

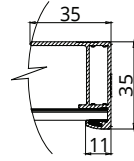

Mounting Hole

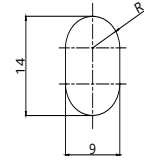

CS1K-330MS / I-V CURVES

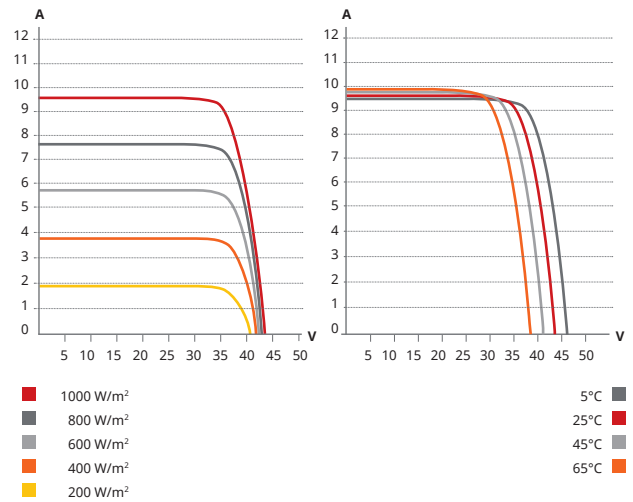

ELECTRICAL DATA | STC*

CS1H	320MS	325MS	330MS
Nominal Max. Power (Pmax)	320 W	325 W	330 W
Opt. Operating Voltage (Vmp)	35.8 V	36.0 V	36.2 V
Opt. Operating Current (Imp)	9.01 A	9.10 A	9.19 A
Open Circuit Voltage (Voc)	43.3 V	43.5 V	43.7 V
Short Circuit Current (Isc)	9.51 A	9.58 A	9.65 A
Module Efficiency	18.98%	19.27%	19.57%
Operating Temperature	-40°C ~ +85°C		
Max. System Voltage	1000 V (IEC) or 1000 V (UL)		
Module Fire Performance	TYPE 1 (UL 1703) or CLASS C (IEC 61730)		
Max. Series Fuse Rating	20 A		
Application Classification	Class A		
Power Tolerance	0 ~ + 5 W		

* Under Standard Test Conditions (STC) of irradiance of 1000 W/m², spectrum AM 1.5 and cell temperature of 25°C.

ELECTRICAL DATA | NMOT*

CS1H	320MS	325MS	330MS
Nominal Max. Power (Pmax)	238 W	242 W	245 W
Opt. Operating Voltage (Vmp)	32.7 V	32.8 V	33.0 V
Opt. Operating Current (Imp)	7.28 A	7.36 A	7.43 A
Open Circuit Voltage (Voc)	40.6 V	40.8 V	41.0 V
Short Circuit Current (Isc)	7.67 A	7.73 A	7.79 A

* Under Nominal Module Operating Temperature (NMOT), irradiance of 800 W/m², spectrum AM 1.5, ambient temperature 20°C, wind speed 1 m/s.

The specification and key features described in this datasheet may deviate slightly and are not guaranteed. Due to on-going innovation, research and product enhancement, Canadian Solar Inc. reserves the right to make any adjustment to the information described herein at any time without notice. Please always obtain the most recent version of the datasheet which shall be duly incorporated into the binding contract made by the parties governing all transactions related to the purchase and sale of the products described herein.

Caution: For professional use only. The installation and handling of PV modules requires professional skills and should only be performed by qualified professionals. Please read the safety and installation instructions before using the modules.

MECHANICAL DATA

Specification	Data
Cell Type	Mono-crystalline, 156.75 × 31.35 mm
Dimensions	1700 × 992 × 35 mm (66.9 × 39.1 × 1.38 in)
Weight	19.2 kg (42.3 lbs)
Front Cover	3.2 mm tempered glass
Frame	Anodized aluminium alloy
J-Box	IP67, 3 bypass diodes
Cable	4.0 mm ² (IEC), 12 AWG (UL),
Cable Length (Including Connector)	1300 mm (51.2 in), 740 mm (29.1 in) is optimal for landscape installation
Connector	T4 series (1000 V)
Per Pallet	30 pieces
Per Container (40' HQ)	780 pieces

TEMPERATURE CHARACTERISTICS

Specification	Data
Temperature Coefficient (Pmax)	-0.37 % / °C
Temperature Coefficient (Voc)	-0.29 % / °C
Temperature Coefficient (Isc)	0.05 % / °C
Nominal Module Operating Temperature	43 ± 3 °C

PARTNER SECTION

