

SERIES 100 UL FLASHED L FOOT KIT

SnapNrack Solar Mounting Solutions

The SnapNrack line of solar mounting solutions is designed to reduce total installation costs. The system's technical innovations have been proven to drive down costs and improve installation quality on more than 350 MW of solar installations.

Flashed L Foot Simplified

SnapNrack Series 100 Flashed L Foot Kit is an innovative solution to provide a long lasting watertight seal over the life of the system. The Flashed L Foot provides a fully flashed roof fastener for attachment to composition roof with no required cutting of shingles. The L Foot is engineered for maximum adjustability for a clean level installation.

- 1" slotted bolt connection
- 1" spacers available for increased adjustability
- Clear or Black anodized aluminum components (both available with black flashing)
- No Cutting of shingles



Flashed L Foot in 4 Simple Steps:

- 1) Locate a rafter in the roof using a pilot drill
- 2) Install base to the roof on top of the composition shingle
- 3) Use a breaker bar to separate the composition shingles above the base, and install the flashing
- 4) Attach the L foot on top and proceed with rail installation and leveling

Place order with your distributor. Purchase material for a single project or order in bulk for additional savings

Patent Pending





Flashed L Foot Kit Parts



Flashed L Foot Kit Assembled

Flashed L Foot Kit Assembly

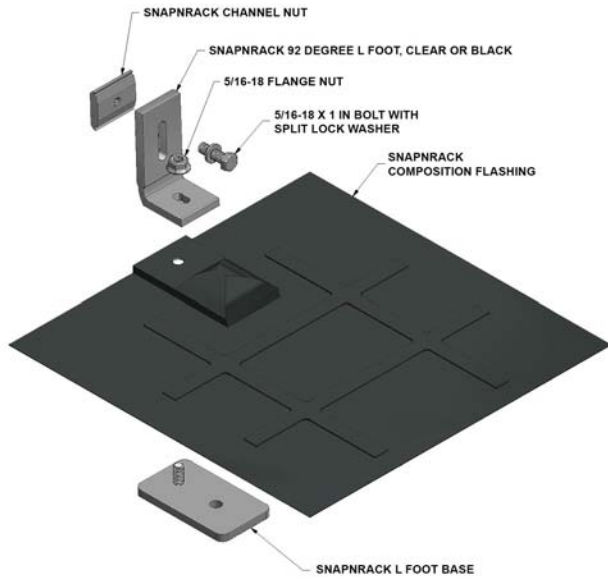

Flashed L Foot Kit Dimensions

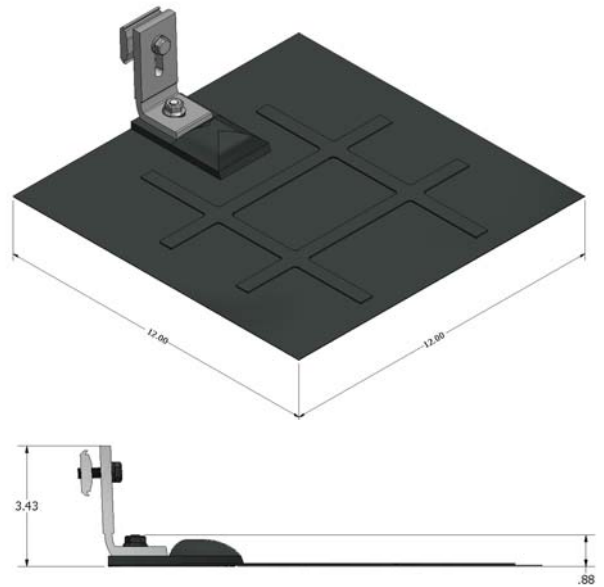

SnapNrack Flashed L Foot Technical Data <small>Patent Pending</small>	
Materials	<ul style="list-style-type: none"> 6000 Series Aluminum L Foot & Base Stainless Steel Hardware Galvanized Steel Flashing w/ black all weather coating
Material Finish	<ul style="list-style-type: none"> Clear and black anodized aluminum
Weight	<ul style="list-style-type: none"> 1.3 lbs
Design Uplift Load	<ul style="list-style-type: none"> 350 lbs Uplift
Design Ultimate Load	<ul style="list-style-type: none"> 1,000 lbs Uplift
Warranty	<ul style="list-style-type: none"> 10 Year material and workmanship



(877) 732-2860 www.SnapNrack.com

Printed on recycled paper using soy based inks.

© 2015 by SnapNrack PV Mounting System. All rights reserved.